

**SPECIFICATION FOR VALVES, HYDRANTS,  
SURFACE BOXES AND MANHOLE COVERS FOR  
WATER SUPPLY APPLICATIONS**

Revised on 25.03.2024

**SPECIFICATIONS FOR  
DI/CI VALVES, HYDRANTS, MANHOLE COVERS AND SURFACE BOXES FOR  
WATER SUPPLY APPLICATIONS.**

<b>TABLE OF CONTENTS</b>	<b>PAGE NUMBER</b>
1.0 General	6m-3
1.1 Ambient Conditions	6m-3
1.2 Suitability for Potable Water	6m-3
1.3 Definitions	6m-3
1.4 Non-metallic Materials	6m-3
1.5 Flanges	6m-3
1.6 Inspection and Testing	6m-4
1.7 Marking of valves & Manhole Covers	6m-4
1.8 Protection during Delivery	6m-5
1.9 Storing handling and hauling of Valves	6m-5
1.10 Packing of bolts, joint rings and gaskets	6m-6
1.11 Manufacturer's Certificate	6m-6
1.12 Quality and workmanship	6m-6
1.13 Flanged Joint Protection	6m-6
1.14 Final Acceptance at site`	6m-6

2.0	TECHNICAL REQUIREMENTS FOR VALVES, HYDRANTS, SURFACE BOXES, MANHOLE COVERS FOR WATER SUPPLY APPLICATIONS	
2.1	Scope	6m - 7
2.2	Definitions	6m - 7
2.3	Reference Standards	6m - 7
2.4	Records and Drawings for Materials to be supplied	6m - 8
2.5	Materials of Manufacture	6m - 9
2.6	Testing	6m - 9
2.7	Coating	6m - 12
3.0	Types of Valves	6m - 12
3.1	Sluice Valves	6m - 12
3.2	Knife Gate Valves	6m - 14
3.3	Butterfly valves	6m - 14
3.4	Air Valves	6m - 17
3.5	Check Valves	6m - 19
3.6	Pressure Reducing Valves	6m - 19
3.7	Pressure Sustaining/Relief Valves	6m - 20
3.8	Flow Control Valves	6m - 20
3.9	Altitude Valves	6m - 21
3.10	Ball Float Valves	6m - 21
3.11	Flap Valves	6m - 21
4.0	Extension Spindles, Tee - Keys and Caps	6m - 22
5.0	Fire Hydrants	6m - 22
6.0	Tools	6m - 24
7.0	Surface Boxes	6m - 24
8.0	Manhole Covers and Frames	6m - 24
	Annex D1 - General components of the single orifice Air Valve	6m - 25
	Annex D2 - General components of the double orifice Air Valve	6m - 26

## **1.0 GENERAL**

### **1.1 Ambient Conditions**

All items of materials and equipment shall be in every respect suitable for storage, installation, use and operation in the conditions of temperature and humidity appertaining in Sri Lanka.

The annual average temperature is 35 °C while the relative humidity varies generally from 70% during the day to 90% at night.

The temperature of potable water to be conveyed in the pipelines will be about 32°C at the depth of 1.5m and all materials of manufacturing shall be suitable for water temperature up to 45 deg.

### **1.2 Suitability for Potable Water**

Valves including their protective coatings and joint materials, that will or may come into contact with potable water shall not constitute a toxic hazard; shall not support microbial growth; shall not cause taste or odour, cloudiness or discolouration of the water and shall be approved by recognized certifying authority listed below, as being suitable for using portable water supply schemes.

NSF International, World Headquarters, 789 N. Dixboro Road, Ann Arbor, MI 48105 USA

Water Regulations Advisory Scheme(WRAS), Fern Close, Pen-Y-Fan Industrial Estate, Oakdale, Gwent, UK, NP11 3EH

IAPMO Research & Testing, 5001 E, Philadelphia St., Ontario, CA 91761-USA.

### **1.3 Definitions**

The definitions given in the relevant standards which are referred to in the specification shall apply for the terms used in this specification.

### **1.4 Non-metallic Materials**

All non-metallic materials supplied shall be listed in the current "Water Fittings and Materials Directory" published by the Water Research Centre, UK, or approved equivalent publication, as a recognized certifying authority having passed full tests of effect on water quality under the requirements for the testing of non-metallic materials for use in contact with potable water.

### **1.5 Flanges**

All flanges dimensionally shall be in accordance with EN 1092-2:1997 Specification for Steel Flanges - Metric Series. The screw threads in all pipes and fittings shall comply with ISO Metric Screw Threads.

## **1.6 Inspection and Testing**

The Contractor shall supply, furnish and prepare the necessary test pieces and samples of all materials and supply the labour facilities and appliances for such testing as may be required to be carried out on his premises according to this specification. If there are no facilities at his own works for making the prescribed tests the Contractor shall bear the cost of carrying out the tests elsewhere.

The Engineer or nominated Inspection authority shall have full access to all parts of the plant that are concerned with the testing, furnishing or preparation of materials for the performance and testing of work under this Specification.

The Contractor shall furnish the Engineer with reasonable facilities and space (without charge) for the inspection, testing and obtaining of such information, as he desires regarding the character of material in use and the progress and manner of the work.

Further all valves shall be tested to the appropriate test pressure at the manufacturer's works and shall be supported by a test certificate from the manufacturer.

The format for test certificate shall be in accordance with the format given in the schedule of particulars.

## **1.7 Marking of Valves & Manhole Covers**

All markings described below shall be legible and durable unless otherwise specified.

The Gate Valve/ Sluice valves, Butterfly valves, Check valves and Hydrants shall be marked in complying with the relevant applicable standard and provisions of BS 5163-1&2:2004, EN 593:2017, BS EN 1074-3:2000 and BS 750:2012 respectively.

All other valves which are not mentioned above but covered under this specification shall be marked with at least nominal size, manufacturer's name (or trade mark), directions of closing, body material designation.

The manhole covers shall be marked in complying with Clause 9 of EN 124-2:2015 and surface boxes shall be marked in complying with Clause 12 of BS 5834-2:2011.

In addition to what is specified above the additional markings and the lettering sizes shall be made with details as per the table below.

Item	Diameter (mm)	Details required	Lettering Heights Details (mm)
Manhole Covers	All sizes	"NWSDB"; "WATER" or "SEWAGE" (whichever is applicable); Standard (BS EN or other); Class or type; Size of clear opening.	50
Surface Boxes	All sizes	As for manhole covers	20
Valves	All sizes	Weight of valve	As appropriate

The Contractor shall label and clearly mark all crates and boxes in indelible paint as specified in the notes forming a part of this Specification.

### **1.8 Protection during Delivery**

All valves and fittings shall be securely packed in crates and boxes to prevent damage during delivery. The cost of packing shall be deemed to be included in the Contract Rates and crates will not be returned.

Each box and package therein shall be clearly labeled stating the number, size and description of the contents.

All details of the proposed method of providing such protection shall be submitted at the time of tendering.

The cost of providing protection to the ends of pipes and fittings shall be included in the unit prices tendered in the Bills of quantities.

### **1.9 Storing, Handling and Hauling of Valves**

All materials shall be stored in an approved location and in such a manner as to preserve their quality and condition.

Storage shall be in accordance with the manufacturers recommendation.

Materials and components shall be handled in such a manner as to avoid any damage or contamination and in accordance with all applicable recommendations of the manufacturers.

The Contractor shall give instructions to the shipper on precautions to be taken in the handling of the valves and other components during loading, towage and unloading, and shall give particulars of these instructions to the purchaser. Also particular attention shall be paid when handling goods to avoid damages to external and internal coatings.

### **1.10 Packing of Bolts, Joint Rings and Gaskets**

Bolts of the same length and size (and their accompanying nuts and washers) shall be packed together in boxes not exceeding 100 kg gross weight.

Joint rings and gaskets shall be packed in boxes and separate packages shall be provided for each size and description of ring or gasket.

### **1.11 Manufacturer's Certificate**

The Contractor shall supply to the Engineer a certificate stating that each item supplied has been subjected to the tests laid down herein and conforms in all respects to this Specification or such other Specification which has been submitted to and approved by the Engineer.

### **1.12 Quality and Workmanship**

The Bidder shall provide ISO 9001:2015 Quality Management System requirement certificate for Quality Assurance for the goods manufacturing factory from an accredited agency for all valves, hydrants, surface boxes, and manhole covers. Accredited Agency shall be a member of International Accredited Forum (IAF) and shall have the authority for the accreditation of mentioned goods in their scope of accreditation. Scope of the production shall be clearly specified in the certificate. Manufacturer shall maintain the validity of this certificate during the supply and delivery of the materials for contract Period. If the supply is made from several factories, ISO 9001:2015 certificates for quality management system requirement shall be submitted for each factory. This certificate shall clearly indicate the location of the place of manufacture of goods.

### **1.13 Flanged Joint Protection**

All sluice valves shall be supplied with complete 'Corrosion' protection materials in accordance with the manufacturer's recommendation. The complete joint protection includes the materials, namely profiling mastic or primer, paste, tape and PVC or polyethylene outer wrapping. The quantity of materials required for each diameter joint shall be calculated in accordance with the manufacturer to cover the whole joint including nuts and bolts. The supplier shall provide the required details of quantities in the schedule of particulars.

### **1.14 Final Acceptance at site**

All valves and accessories shall conform to the specification at site. Engineer shall carryout necessary inspections at site prior to final acceptance.

## **2.0 TECHNICAL REQUIREMENTS FOR VALVES, HYDRANTS, SURFACE BOXES, MANHOLE COVERS FOR WATER SUPPLY APPLICATIONS**

### **2.1 Scope**

This section covers the requirements for the supply of valves, hydrants, surface boxes and manhole covers.

Accessories associated with the valves are also specified.

### **2.2 Definitions**

The definitions given in the relevant standards, which are referred to in the specification, shall apply for the terms used in this specification.

### **2.3 Reference Standards**

The following standards are referred to in this section;

EN ISO 1461:2009	Hot dip galvanized coatings on fabricated iron and steel articles. (Specifications & test methods)
BS EN 1982:2017	Copper and copper alloys - Ingots and castings
BS EN 1092-2:1997	Flanges and their joints- Circular flanges for pipes, valves, fittings and accessories, PN designated for Cast iron flanges
BS EN 1563:2018	Specification for Spheroidal graphite cast irons
BS EN 1561:1997	Grey Cast Iron
BS EN 593:2017	Industrial valves- Metallic butterfly valves for general purposes
BS 5163-1&2:2004	Predominantly Key-operated cast iron gate valves – Code of practice & Stem caps for use on isolating valves & associated water control apparatus- Specification
BS 5834-2:2011	Specifications for small Surface boxes. Surface Boxes, guards and underground chamber for gas and water work purposes.
BS EN 124-1:2015	Gully tops and manhole tops for vehicular and pedestrian areas. Definitions, classification, general principles of design, performance requirements and test methods.
BS EN 124-2:2015	Gully tops and manhole tops for vehicular and pedestrian areas. Gully tops and manhole tops made of cast iron.



ANSI /AWWA C 502-80	Dry Barrel Fire Hydrants
BS EN 558: 2017	Industrial Valves – Face-to-face and centre-to-face dimensions of metal valves for use in flange pipe systems- PN and class designated valves.
BS EN 1074-1: 2000	Valves for water Supply-Fitness for purpose requirements and appropriate verification tests: General Requirements.
BS EN 1074-2: 2000	Valves for water supply- Fitness for purpose requirements and appropriate verification tests: Isolating valves.
BS EN 1074-3: 2000	Valves for water supply- Fitness for purpose requirements and appropriate verification tests: Check valves.
BS EN 1074-4: 2000	Valves for water supply- Fitness for purpose requirements and appropriate verification tests: Air valves.
BS EN 681-1:1996	Elastomeric seals - Material requirements for pipe joint seals used in water and drainage applications: Vulcanized rubber
ISO 4633:2015	Rubber seals - Joint rings for water supply, drainage and sewerage pipelines - Specification for materials
ISO 5208: 2015	Industrial Valves – Pressure testing of metallic valves
BS 750:2012	Specification for underground fire hydrants and surface box frames and covers
BS EN 10088:2015	Stainless Steel

#### **2.4 Records and Drawings for Items (Valves and other Ancillary items) to be supplied**

The following records and drawings of all types of valves shall be made available by the supplier for inspection.

- Drawings showing overall dimensions, valve construction and settings
- Data related to pressure ratings, weights and materials of manufacture (each component)
- Test certificates of works tests
- Performance data of air valves
- Seating design and the seating materials of butterfly valves

## 2.5 Materials of Manufacture

All materials of manufacture shall be suitable for use with water at temperatures up to 45 deg. C.

Valve body casting shall be ductile iron of GJS-400-15 or higher grade complying with EN 1563:2018 for diameters 50mm and above, while brass valve body casting is acceptable for below DN50 and shall be capable of withstanding the test pressures specified. The castings shall be close grained, sound, smooth and symmetrical, and shall be carefully cleaned and dressed off. No stopping or plugging will be permitted in the case of air holes appearing in the castings.

Unless otherwise specified, all standard valves shall be flanged type where flanges shall be of PN 16 and complying with EN 1092-2 :1997.

The direction of closing of valves shall be "clockwise" and hand wheels shall be permanently marked with the words "open" and "closed" and a direction arrow.

All materials shall comply with the appropriate British Standards or equivalent. All castings shall be free of blowholes and other defects.

Sluice valves and butterfly valves shall be suitable for flow in either direction.

All standard valves shall be suitable for frequent operation and for infrequent operation after long periods in the open or closed condition.

All non-metallic materials to be provided shall be as listed in the current "Water Fittings and Materials Directory" published by the Water Research Centre, UK, or approved equivalent publication, as having passed full tests of effect on water quality under the requirements for the testing of non-metallic materials for use in contact with potable water.

The Engineer shall have the right to reject any casting, forging, bearing etc and the contractor shall replace any such defective parts at his own expense.

## 2.6 Testing

### **General**

The manufacturer shall notify the Engineer at least thirty working days prior to factory tests. The Engineer reserves the right to witness all tests.

### **(i) Performance Test**

Each valve, gate and appurtenance shall be shop-operated three times from the fully closed to the fully opened position, and the reverse, under a no-flow condition, to demonstrate that the complete assembly is workable.

(ii) **Leakage Test (Closed Position)**

(a) **For Internal Pressure**

Valves, gates and appurtenances shall be shop-tested for leaks in the closed positions. The hydrostatic pressure shall be applied to one face of the disc for the full test duration at the working pressure when the valve is in closed position. This shall be repeated to the other face of the valve too. The length of test shall be at least 3 minutes and there shall be no indication of leakage past the valve during the test period. The test pressure shall be given in the Table below.

<i>PN</i>	<i>Test Pressure (PFA) (Bars)</i>	<i>Duration (Minutes)</i>
16	25	3
25	35	3

(b) **For External Pressure**

Valves shall be leak tight to ingress of air, water or any other foreign matter.

(iii) **Hydrostatic Test**

Valves specified shall be hydrostatically tested. Hydrostatic tests shall conform to the following;

With the valve disc in fully open and a slightly open position, internal hydrostatic pressure equivalent to 150% of the specified working pressure as specified in the table below shall be applied to the inside of the valve body of each valve for a period of 3 minutes. During the hydrostatic test, there shall be no leakage through the metal, the end joints, or the valve shaft seal; nor shall any part be permanently deformed. While undergoing testing, the valve body shall be struck with a hammer several times.

<i>PN</i>	<i>Test Pressure (PFA) (Bars)</i>	<i>Duration (Minutes)</i>
16	25	3
25	35	3

(iv) **Seat Tightness Test**

<b>Type of valve</b>	<b>Test Procedure</b>
Sluice valve Ball float valve Knife Gate valve	<ol style="list-style-type: none"><li>1. Fill in the valve cavity including if appropriate, the bonnet cavity with water.</li><li>2. Move the obturator to the closed position.</li><li>3. Apply the test pressure, which is 1.1 times the allowable differential pressure at room temperature, and maintain the test pressure for 3 minutes.</li><li>4. Determine the leakage rate.</li><li>5. Repeat 3 and 4 inclusive for the other side of the valve. <i>See NOTES 1,2,3 and 4,6</i></li></ol>
Butterfly Valve	<ol style="list-style-type: none"><li>1. Fill the valve cavity with water.</li><li>2. Move the obturator to the closed position.</li><li>3. Apply the test pressure, which is 1.1 times the allowable differential pressure at room temperature in the direction to unseat the obturator and maintain the test pressure for 3 minutes.</li><li>4. Determine the leakage rate. <i>See NOTE 5&amp;6</i></li></ol>
Check Valve	<ol style="list-style-type: none"><li>1. Fill in the downstream valve cavity including, if appropriate, the cover cavity with water.</li><li>2. The test pressure, which is 1.1 times the allowable differential pressure at room temperature in the direction tending to close the obturator and maintain the test pressure for 3 minutes.</li><li>3. Determine the leakage rate. <i>See NOTE 6</i></li></ol>
<p><b>NOTE</b></p> <ol style="list-style-type: none"><li>1. <i>The procedure described may not ensure pressurization of the integrate space of double seated valves and may not therefore permit verification of the leakage rate of the downstream seat. When such pressurization is a requirement of the product or performance standard or is required by the purchaser, it is necessary to carry out step 3 before step 2.</i></li><li>2. <i>Valves which incorporate “double block and bleed” design feature have the bleed plug removed prior to the test in order to prove the “double block and bleed” capability.</i></li><li>3. <i>Valves with independent double seating (such as two piece obturator or double-seated valves) may be tested by applying the test pressure between the seats and checking each side of the closed valve.</i></li><li>4. <i>Soft seated ball float valves previously subjected to a liquid seat test pressure may have a reduced performance capability in some subsequent services at low differential pressures. If a liquid seat test pressure is specified and is carried out before a low pressure gas seat test, it may be necessary to allow time for the seat material to recover.</i></li><li>5. <i>Valves with symmetrical seating may be tested in either direction.</i></li><li>6. <i>Testing shall be carried out accordance with the EN 1074:2000 or EN 593:2017 or ISO 5208:2015.</i></li></ol>	

(v) **Field Testing**

When the valves, gates and appurtenances have been completely installed and as soon as operation conditions permit, they shall be given a field test by the Engineer to demonstrate that they have been suitably installed, that they meet all requirements, are in good operating condition and are, in every way, adequate for the service intended.

**2.7 Coating**

All exposed cast iron or ductile iron components of valves to the external environment or to the water contained in the valve shall be fully coated to provide protection against corrosion.

The external and internal surfaces except mating surfaces of all valves shall be treated with an epoxy coating, a bitumen solution or any other material acceptable to the purchaser at the place of manufacture. Threaded and exposed machined surfaces liable to rusting shall be adequately protected in accordance with BS 5163-1&2:2004.

**3.0 Types of Valves**

**3.1 Sluice Valves**

The sluice valves for pipeline installation shall comply with EN 1074-1&2:2000 and shall be of PN 16 pressure rating or as specified in the BOQQ, for potable water applications. Flanges shall confirm the EN 1092-2:1997.

The valve body shall be brass below diameter DN 50 complying with BSEN 1982:2017. For diameters DN 50 and above, the valve body shall be ductile iron of GJS-400-15 or higher grade complying with EN 1563:2018.

Valve spindles shall be of the internal non-rising type.

Sluice valves shall be standard inside screw, wedge gate valves with resilient seating for diameter from DN 50 – DN 300 inclusive and metal to metal seating from diameters above DN 300.

Valves shall have stainless steel stems, machined bronze or gunmetal mating faces securely fixed to the valve body, stuffing box and gland type or approved type stem seal, EPDM seals confirming to EN 681-1:1996 or ISO 4633:2015 type WA at joints between castings.

All Key operated valves shall be provided with Tee-Key/Ring key and valve cap as per BS 5163-1&2:2004.

By pass arrangement shall be provided for valves of DN 300 and above.

Directions of closure of the valves shall be “clockwise”. In case of hand wheel operated valves, hand wheels shall be made of cast iron and shall have arrows and words ‘open’ and ‘close’ cast on to indicate direction of rotation for opening and closing the valve.

The maximum differential pressure in operation for valves shall be as given in items description of the valves in the BOQQ or as given in the drawings. Where necessary valves above diameter DN 300 shall be provided with gearing to achieve the designed manual operation of valves where it should be assumed that the maximum torque exerted by one man is 130 Nm. In additionally for power operation, provision shall be made for fitting electric actuators where specified.

Motorized (Motor operated) valves shall be provided for diameters DN 500 and above as given in the item description of BOQQ or as given in the drawings.

All sluice valves shall be subjected to all type testing in accordance clause 1.6 hereof including 'open ended' works test of which the test certificates issued by the manufacturer to this effect, shall be submitted.

The face-to-face (FTF) dimensions of the sluice valves as specified in EN 558: 2017 shall be as follows.

**Sluice Valves - Series 3**

Diameter (mm)	FTF dimension (mm)	
	PN 10 / PN 16	PN 25
10	102	-
15	108	140
20	117	152
25	127	165
32	140	178
40	165	190
50	178	216
65	190	241
80	203	283
100	229	305
125	254	381
150	267	403
200	292	419
250	330	457
300	356	502
350	381	572
400	406	610
450	432	660
500	457	711
600	508	787
700	610	-
800	660	-
900	711	-
1000	813	-

### **3.2 Knife Gate Valves**

Knife gate valves are used mainly for isolation duties, with a sharp edge to slice through the mash and seal.

The valves shall be suitable for the above ground or set in chamber submerged duty applications.

Valves shall be fitted with an elastomer seal suitable for flow in either direction and shall be leak tight in both directions. The seal material shall be suitable for drinking water.

The valve body shall be ductile iron complying with EN 1563:2018 or cast iron complying with EN 1561:1997 up to and including DN 150. For diameters above DN 150, the valve body shall be ductile iron complying with EN 1563:2018. Valves shall have stainless steel stems and knife gate conforming to EN 10088-1:2015 and ductile iron yoke conforming to EN 1563:2018. The valve seat shall be EPDM seals conforming to EN 681-1:1996 or ISO 4633:2015 type WA.

Materials of construction shall be selected to avoid electrolytic corrosion erosion, and be approved for use with potable water. To prevent corrosion on submerged duties, the internal and external surfaces of the valve body shall be coated with an approved coating conforming to WIS - 4-52-01 or equivalent.

Valve bodies shall be capable of withstanding 1.5 times the rated pressure with the gate open, and the rated pressure with the gate-closed. Flanges shall be to BS EN 1092-2:1997.

Directions of closure of the valves shall be 'clockwise'. In case of hand wheel operated valves, hand wheels shall be made of cast iron and shall have arrows and words 'open' and 'close' cast on to indicate direction of rotation for opening and closing the valve.

Valves for above ground duty may have soft packing type spindle seals, but valves for submerged duty shall have seals fitted that prevent leakage and the ingress of contaminants.

Valves shall be designed to allow stem seals to be repacked or replaced.

Actuated valves shall incorporate a robust guide mechanism to ensure shaft alignment under all operational scenarios. For hand operation the valves shall be fitted with a cap suitable for use with a key and bar, or a hand wheel where specified. For power operation, provision shall be made for fitting electric actuators where specified.

### **3.3 Butterfly Valves**

Standard butterfly valves shall conform to EN 593:2017 for PN 16 (i.e. 16 bar) pressure rating and EN 1074-1 & 2:2000. However higher PN range shall be provided as given in the item of BOQ.

Except where otherwise specified, all butterfly valves shall be equipped with manual operators with hand wheels and shall be resilient seated and shall give tight closure against unbalanced water pressure in either direction. The unbalanced water pressure shall be the design pressure rating of the valve.

The valve body shall be ductile iron complying with EN 1563:2018 and shall be designed to withstand the maximum working pressure specified and the maximum differential pressure of 0.6 MPa.

The manufacturer's preferred direction of flow for the valve shall be clearly marked on it.

The valve seat shall be replaceable and be formed of EPDM conforming to EN 681-1:1996 OR ISO 4633:2015 type WA or other approved resilient material. Seats shall be of a design that permits removal and replacements at the site of installation. The valve seat shall be securely clamped into a machined groove in the valve body or to the edge of the disc by seat retention members or other equivalent retention device, in such a manner as to prevent leakage of water under the seats and to hold the seat securely in position during opening and closing of the valve disc. The seat retention members shall be of stainless steel and shall be securely fastened to the body or disc with stainless steel fasteners.

The valve disc shall be made of ductile iron. Disc edges shall be machined with rounded corners and shall be polished to a smooth finish. The valve disc shall rotate through an angle of 90 degrees from the fully opened to the fully closed position and the seat shall be of such design as to allow the valve disc to seat at an angle normal to the axis of the pipe when the disc is in the fully closed position. Adjustable mechanical stops shall be provided in the valve body to be capable of absorbing full operating torque with a minimum design safety factor of 5 (five).

The shaft and nuts and bolts shall be fabricated of stainless steel complying with relevant provisions of EN 10088:2015 The shaft and disc fixing shall be capable of absorbing the full operating torque with a minimum design safety factor of five. Shaft seals, when used, shall be EPDM rubber O-ring type. Packing shall be either rubber O-ring or self-adjusting chevron type.

When all the seat retention members are in place, the finished edges shall fit closely and the surface shall be smooth with all fastenings set flush in the water passage so as to offer the least resistance possible to the flow of water through the valve.

Valve seats which extend over the face of the flanges to secure the seat in place, or which require surface grinding and/or hand fitting of the disc; or designs which require the adjoining pipe flange to retain the seat in place and resist line pressure, shall not be supplied.

Operating gear for butterfly valves shall be of the fully enclosed type. Valves shall be suitable for operation by one man at all pressure conditions that can apply. A valve position indicator shall be provided for butterfly valves in chambers. Where a hand wheel is used for operating such a valve, the indicator shall be clearly visible from the



hand wheel operating position. Where a containing chamber is not shown, butterfly valves shall be specially adapted for buried use. Inline valves shall be operated by means of a hand wheel or tee key and be provided with gearing to prevent rapid closure of the valve. Gear ratios shall be at least 20:1. The valve bodies shall be protected by a bitumen coating and the valve discs by a Nylon Coating or similar.

All butterfly valves shall be tested at the manufacturer's works in accordance with EN 593:2017 and EN 1074-1&2:2000 as specified here and as per clause 1.6 above and under 'open-end' conditions. The seat test shall be for tight closure under maximum unbalanced water test pressure in either direction. The maximum permissible leakage for each valve shall be 0.05 liter per hour per 100 mm nominal diameter of the valve. The word "CLOSE" or its abbreviation and the arrow mark indicating the direction of rotation to close the valve shall also be cast on the cover of the body.

The face-to-face (FTF) dimensions of the sluice valves as specified in EN 558: 2017, Table 4 shall be as follows;

<b>Diameter (mm)</b>	<b>FTF dimension (mm)</b>	
	<b>PN 2.5,6,10,16,25</b>	<b>PN 40</b>
40	106	140
50	108	150
65	112	170
80	114	180
100	127	190
125	140	200
150	140	210
200	152	230
250	165	250
300	178	270
350	190	290
400	216	310
450	222	330
500	229	350
600	267	390
700	292	430
800	318	470
900	330	510
1000	410	550
1200	470	630
1400	530	710
1600	600	790
1800	670	870
2000	760	950

### 3.4 Air Valves

All air valves for water supply shall comply with the EN 1074-1 & 4:2000. Air valves shall be constructed so that internal working parts, which may become necessary for repairs shall be readily accessible, removable and replaceable without use of special tools and removing the valve from the line.

Standard air valves shall be designed so that the floats seat against orifices without leakage at all pressures between 0.1 bar and the maximum field test pressure. The design for the floats and seats shall be such that the risk of adhesion is a minimum and shall be of a type proved by experience to be suitable for the duties required.

All valves shall be suitable for operation under working pressures conforming to clause 4.3 : Table 1 of EN 1074-1 and 4 :2000, Valves shall be so designed that the floats cannot be held or blown shut against the orifices by air pressure or turbulence due to escaping air.

The air valves should be equipped with protective coatings or other measures to prevent corrosion, ensuring long-term durability and reliability in the potable water supply system.

Standard air valves shall have a minimum pressure rating of 16 bars and in all cases Flanges shall be with PN 16 (i.e. 16 bars), complying with EN 1092-2: 1997.

#### 3.4.1 Single Orifice Type

Single orifice type air valve shall be of cast iron or ductile iron body and single float actuated air valves with flanged ends.

Small orifice air valves shall have an orifice diameter of not less than 1.5 mm and shall be designed for automatically releasing air accumulated in pipelines during normal working conditions so as to prevent accumulations of air interfering with pipeline capacity. Small orifice air valves shall be provided with an isolating valve.

The design of the single orifice type valve shall be capable of efficient and quick air release facility, maintaining the system's hydraulic efficiency as well as preventing the buildup of air pockets that can impede water flow.

General components of the single orifice air valves is given in Annex D1.

Large orifice air valves shall be required to release or admit air while the pipeline is being filled or emptied and also to perform surge control functions. The airflow characteristics of air valves shall be in accordance with EN 1074-1 & 4:2000.

Large Orifice air valves shall be provided with separate isolating valve.

### 3.4.2 Double Orifice Type

Double Orifice Air valves shall comprise one large orifice air valve and one small orifice air valve integrated into a single unit assembly and having a single pipeline connection. It shall have cast iron or ductile iron body and double float actuated air valves with flanged ends.

The valve shall be designed to automatically release air during pipeline filling and to intake air when the system is drained or when water column separation occurs, thereby preventing issues such as vacuum formation and pressure fluctuations.

Double orifice air valves shall be provided with a separate isolating valve. Isolating valves must be so arranged that they can be closed from the ground surface above, with a tee key even when the air valve chamber is flooded. Where required, a short length of double-flanged pipe could be supplied to increase the height above the main to suit the operational requirements depending on the depth of installation of Air valve. Air valves shall be insect proof at the outlet vents leading to the atmosphere.

Tests shall be carried out on all types of air valves, as specified in EN 1074-1 and 4:2000 and as mentioned below and the contractor shall submit the manufacturer's certificates certifying that such tests have been conducted satisfactorily. General components of Double Orifice Air Valve is given in Annex D2.

(a) Body Strength Test

Each complete valve shall be water tested for strength using a test pressure 1.5 times the specified working pressure. No damage or permanent deformation of the valve body, ball or seat shall occur and there shall be no leakage through the metal or any joints of the body.

(b) Leakage Test

Each complete valve shall be water tested at all pressures between 0.1 bar and the maximum field test pressure for the valve and the seat shall be drop tight throughout this range of pressure.

(c) Performance Tests

One valve of each size shall be tested as follows;

- (i) Air shall be introduced under the flange at the minimum outflow rate specified above for the size of pipeline being tested. The pressure difference required to maintain this flow shall not be more than 0.5 bars.
- (ii) Air shall be exhausted from beneath the flange at the minimum inflow rate specified above for the size of valve being tested. The pressure difference required to maintain this flow shall not exceed 0.2 bars.

All air valves shall be coated as given in clause 1.7 above.

### 3.5 Check Valves

Unless otherwise specified, check valves shall be swing type conforming to EN 1074-1 and 3 :2000 with a pressure rating of PN 16 (i.e. 16 bar) or as specified in the BOQQ. The design shall be facilitated for reliable operation, minimal head loss, and effective prevention of backflow in the water supply system. Check valves shall be constructed so that disc, seat, seat rings and other internal working parts, which may become necessary for repairs, shall be readily accessible, removable and replaceable without use of special tools and removing the valve from the line. The valve body and the disc shall be of ductile iron complying with EN 1563:2018 and having smooth operating stainless steel hinge pins with gun metal bushes, EPDM encapsulated discs. They shall possess high speed closing characteristics with minimum shock on closing. All valves shall be tested to EN 1074-1 and 3 :2000 and the test certificates issued by the manufacturer shall be submitted. All check valves shall be coated to as specified in clause 2.7 hereof. The flange drilling shall comply with EN 1092-2:1997.

### 3.6 Pressure Reducing Valves

Pressure reducing valves shall be designed to reduce a constant or variable inlet pressure to a predetermined constant outlet pressure, at flows varying from the maximum capacity of the valve to zero flow.

All valves shall be suitable for use with water temperature up to 40<sup>0</sup>C and in climatic conditions encountered in Sri Lanka such as humidity 85%, dusty environment, corrosive atmosphere etc. Valves shall be minimum rating of 10 bars and shall provide to higher ratings of 16, 25 or 40 when specified in the item of BOQ.

The valve operation shall be achieved by the inter-action of the inlet pressure, outlet pressure and an intermediate pressure, which is produced by a pilot valve or relay system acting on the upper side of the main valve. Other equally effective and reliable systems may be accepted by the Engineer. Operating primary pressure of 16 bar and at an adjustable secondary pressure range of 25 or 40 bars shall be as specified in the BOQ.

The pilot valve or relay system shall be actuated by a diaphragm connected to the outlet pressure on its underside and a constant pressure on its upper side derived either from weights or from a spring. The weights or spring shall be capable of an adjustment. Gauge indicating upstream pressure and downstream pressure shall be incorporated. Two pressure gauges shall be provided with the valve.

Nominal pressure rating shall be 16 bars, unless otherwise stated.

Body ends shall be flanged and drilled to EN 1092-2:1997, with a pressure rating of PN 16. Materials for construction of the valve shall be ductile iron, grey cast iron, stainless steel (SS316 or higher) or Equivalent and shall be non-corrodible, hard wearing and suitable for use with potable water. Gunmetal, aluminum bronze and stainless steel shall be used for internal components.

Marking of valves shall include the manufacturing standard; manufacturer's name or trademark; nominal diameter (DN) in mm; pressure rating in bars; Flow direction; an individual serial number which relates directly to the manufacture's test certificate; and month and year of manufacture.

All valves shall be tested to the appropriate test pressure as specified in Clause 4.3 of EN 1074 – 1: 2000 and as given below at the manufacturer's works, and shall be supported by a test certificate from the manufacturer. The Supplier shall provide the original manufacturer's test certificate. The certificate shall relate to the individual number cast on each valve and shall give the date of test and the performance of test with test pressure and the time.

<i>PN</i>	<i>Test Pressure (PFA) (Bars)</i>	<i>Duration (Minutes)</i>
16	25	3
25	35	3

### **3.7 Pressure Sustaining/Relief Valves**

Pressure sustaining valves shall be capable of maintaining a constant pressure in the main upstream of the valve. They may be used to reduce excess pressure when installed in a branch main.

Operation shall be achieved in a similar manner to the pressure reducing valve except that the relay system shall be actuated by the upstream pressure.

Manufacturing of the valve shall generally be in accordance with the specification for pressure reducing valves.

Testing shall be carried out according to clause 1.6 hereof.

### **3.8 Flow Control Valves**

Flow control valves shall be designed to prevent the rate of flow rising above that specified for the particular application, regardless of the operating pressure in the system upstream or downstream of the valve.

Flow control valves shall be equipped with reliable sealing mechanisms to prevent any leakage or water loss, ensuring the efficient and effective regulation of water flow while maintaining the overall integrity of the water supply system. Valves shall be designed for ease of maintenance, including straightforward disassembly and reassembly procedures for cleaning and repairs.

The valve operation shall be achieved by the operation of a relay system responding to the pressure difference measured across an orifice in the flow upstream of the valve.

The manufacturing of the valve shall be generally in accordance with that specified for pressure reducing valves above.

### **3.9 Altitude Valves**

Altitude valves shall be designed to control inflow into an overhead tank or reservoir, the valve being installed in the main line to the tank and controlled by a small diameter ball valve in the tank, so that when the tank is full, the ball valve closes, which in turn shuts the main valve. The valve operation shall be achieved by the interaction of the inlet pressure, the pressure in a small bore pipe in to the ball cock and an intermediate pressure produced by a pilot valve or relay system acting on the upper side of the main valve which in turn shuts the main valve.

The pilot valve or relay system shall be actuated by a diaphragm connected to the small bore pipeline to the ball valve on its underside and having a constant pressure on its upper side derived from either weights or a spring. Manufacturing of the valves shall generally be in accordance with the specification for pressure reducing valves.

### **3.10 Ball Float Valves**

Ball float valves shall be designed for installation on the inlet pipe to a storage tank to shut the water off automatically when it reaches a predetermined level. They shall be of the single or double beat type or pilot operated with direct float and lever operation.

Valves shall be designed for the working pressure specified and shall be tested for leakage at that pressure, when they should be drop tight. They shall be tested for body and valve element strength with the valve closed and a test pressure 1.5 times the working pressure applied to the inlet end.

The body end shall be flanged, faced and drilled to EN 1092-2 : 1997

Valves shall not contain brasses containing more than 5% zinc. Gunmetal (to EN 1982:2017 Grade LG 2), aluminum bronze or nickel copper alloy may be used for internal components.

The body or stopper shall be of ductile iron or grey or Meehanite cast iron.

Floats shall be copper or glass fibre. The lever and links shall be of mild steel with bronze pins.

Where a stilling tank arrangement is required it shall accommodate a cheese type float mounted on a central tube connected to the valve operating lever and sliding vertically on a guide rod secured to the base of a galvanized wrought iron cylindrical tank perforated at the base.

### **3.11 Flap Valves**

Flap valves shall have frames and doors of ductile iron to EN 1563:2018, sealing faces of gunmetal to EN 1952:2008 Grade LG 2 or LG 4 and hinge pins and links of ductile iron, steel nickel iron or stainless steel. They shall be flanged for mounting to pipe work or bolting to concrete. Sealing surfaces of flaps and frames shall be of non-

ferrous metal (excluding aluminium) accurately machined to ensure a watertight fit in the closed position. All flaps shall be double hung and seat off the vertical.

In case of plastic flap valves they shall have doors constructed from non-toxic, ultraviolet stabilized, flexible reinforced plastic material and the frames shall be fabricated from mild steel, blast cleaned and painted with 25 microns of two pack epoxy blast primer and one 75 micron coat of micaceous iron oxide two pack epoxy.

All immersed steelwork shall be hot dipped galvanized to EN ISO 1461:2009 or as appropriate. Nuts and bolts shall be hot dipped galvanized.

Flanges shall be of PN 16 conforming to EN 1092-2: 1997., coated in either fusion bonded epoxy, minimum thickness 150 microns or cold applied black bitumen.

#### **4.0 Extension Spindles, Tee - Keys and Caps**

The depths of installation of all valves are as indicated in the BOQ descriptions (or as shown on the drawings) and a Tee - Key for the operation of valves shall be supplied in the following manner.

Four Tee - Keys for each size of valves to be supplied. The maximum length of Tee key shall be limited to 1m and Valves shall be provided with extended spindle to the Valve.

The material of Tee - Keys shall be galvanized mild steel.

In case extension spindles are necessary, extension spindles shall be provided with suitable bearings, which are rigidly held on brackets or stays. Bearings and extension spindles shall be suitably protected against corrosion.

Where a valve does not require an operating or extension spindle, the valve spindle shall be protected with a properly fitting cap as per BS 5163-1&2:2004.

#### **5.0 Fire Hydrants**

##### **General**

Fire hydrants shall be supplied and installed at the locations shown on the key plan and drawings and distribution pipelines. The exact locations of the fire hydrants shall be identified at site in the presence of the Engineer's Representative and approved by the Engineer.

##### **(a) Screw down Type**

Screw down fire hydrants shall conform to BS 750: 2012 (type 2) with "captive" internal valve. The hydrant body material shall be ductile iron, which complies with EN 1563:2018.

The inlet flange shall be of PN 16 complying with BS EN 1092-2: 1997 and shall be faced and drilled to table 'E' of BS 10:2009. The outlet piece shall be

Gunmetal complying with EN 1982:2017 Grade LG 2 or stainless steel complying to EN 10088-1:2015 with minimum chromium content of 13% or copper alloy. The hydrants shall be of round threaded conforming to BS 750:2012.

The hydrant body shall be capable of withstanding a pressure of 24 bars and the valve and seat pressure of 16 bars. The test certificates of body and seating tests shall be submitted.

The outlet cap shall be of polypropylene or equivalent, without threads and shall be securely attached.

The direction of closing of hydrant valve shall be clockwise.

(b) Dry - Barrel Type

Dry-Barrel type Fire Hydrants shall comply with ANSI/AWWA C 502-80 standards or an equivalent with the following requirements;

- i. Buried length shall be 4.5 feet. (1.35m)
- ii. Number of hose and pump outlet nozzles shall be two.
- iii. 2.5 inches (63.5 mm) nominal inside diameter two number outlet nozzles shall be provided with round threads to BS 750:2012.
- iv. Size of hydrant shall be 4 inches (100 mm).
- v. Inlet connection shall be 6 inches (150 mm) in diameter flange type (side inlet). Suitable Double Flanged Ductile Iron Reducers shall be supplied to connect the Fire Hydrants to the existing pipe diameter flanges.

The bonnet, foot piece or elbow, packing plate, gate, bottom plate and outlet nozzle cap should be of ductile iron while miscellaneous structural parts can be grey iron, ductile iron or malleable iron. Valve seats, seat rings for the main valve and the drain valve and outlet nozzle shall be made of grade A,B, D or E bronze. The threaded portion of the operating stem or threaded stem nut (or sleeve) shall be made of grade A, B, C, D or E bronze too. The Supplier shall supply the necessary gaskets, conforming to BS EN 681-1:1996 and nuts, bolts and washers for the 6 inches (150 mm) flange joint between the reducer and the Fire Hydrant.

- vi. Direction of rotation of the operating wheel to open the hydrant shall be counter clockwise.

- vii. Colour of the finish paint above the ground line shall be red.

- viii. The following parts may be made out of grey or ductile cast iron, but the Bidder has to submit with the tender the material he is going to use: Barrel,



top or bonnet, foot piece or elbow, packing plates, gates, bottom plates, outlet nozzle caps and miscellaneous structural parts.

## **6.0 Tools**

The Contractor shall supply two complete sets of tools adequate for the erection and maintenance of all valves, hydrants and other fittings supplied.

## **7.0 Surface Boxes**

Surface boxes shall be Ductile Iron, Grade “A” heavy duty complying to Table 1: Surface box grades of BS 5834-2:2011 with the minimum clear opening of 100mm, 135mm or 225mm depending on the location and as specified in the BOQQ.

Surface boxes shall be painted before installation with two coats of bituminous paint.

They shall be with captive hinge arrangement to prevent vandals and with suitable watertight arrangement to prevent ingress of surface water into the keyhole. The hinge pin shall be made from stainless steel manufactured to suit the design and dimension of the unit. The diameter of the hinge pin shall not be less than 6mm.

The lids or covers of surface boxes shall have cast in-letters of words in English and the marking “NWSDB – WATER” in suitable size, cast in raised letters.

## **8.0 Manhole Covers and Frames**

Manhole covers / gratings and frames shall be of class D 400 as per the Table 4: Test Loads of BS EN 124-1: 2015 unless otherwise stated. They shall be made from Ductile Iron coated with black bitumen. Couplings, nuts & bolts, etc. shall be hot-dip galvanized. Material in a frame, grating or cover used to prevent a non - rock seating.

Clear opening of manhole cover shall be 600 mm unless otherwise stated in the drawings and BOQQ.

Manholes covers shall be with suitable watertight arrangement to prevent ingress of surface water into the manhole. The keyways shall be lockable type with captive hinge arrangement to prevent vandals. The locking arrangement shall be demonstrated in catalogues/ technical literature/ drawings.

The covers shall be ventilating or non-ventilating.

Manhole covers for air valves and washouts shall be ventilated type whereas Manhole covers for sluice valves shall be watertight and hence shall be non-ventilating type.

Manhole covers for fire hydrants shall comply with requirements of fire authority.

The manhole covers shall have letter or words in English and the marking “NWSDB – WATER ” in suitable size, cast in raised letters.

General Components of the Single Orifice Air Valve

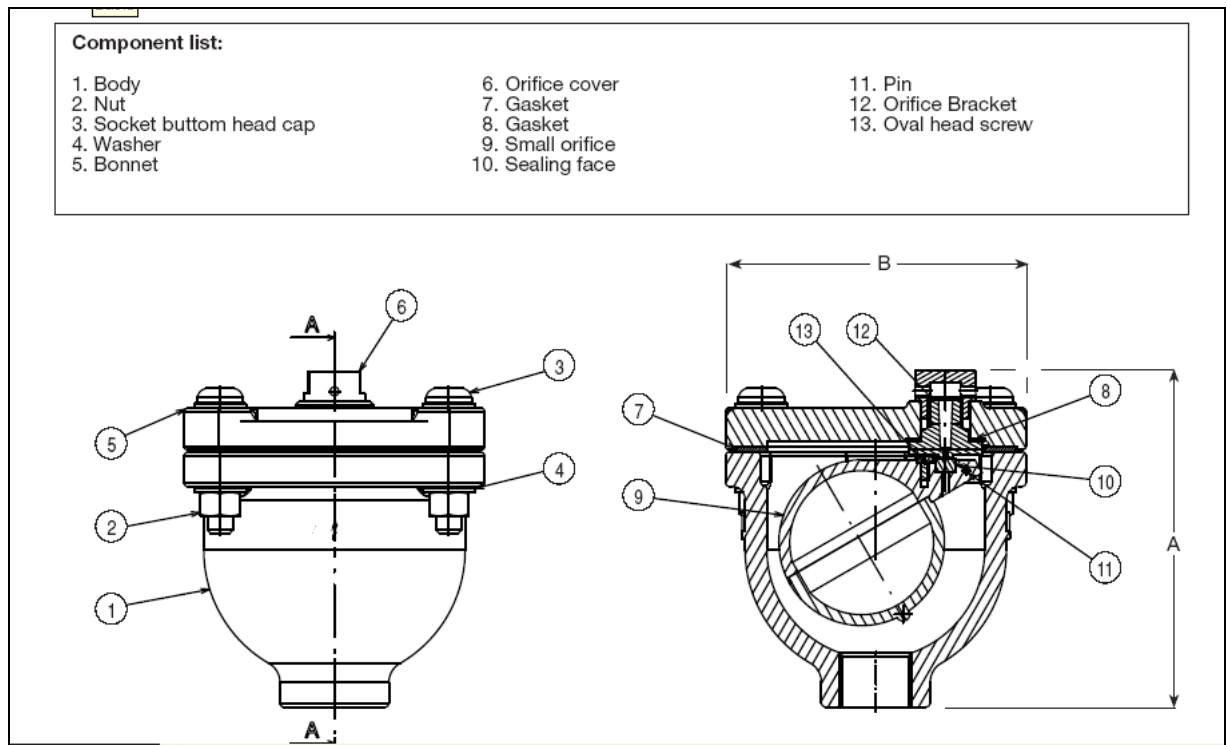

**General Components of the Double Orifice Air Valve**

