

REVISED ON 17-01-2024

**THE GOVERNMENT OF THE DEMOCRATIC SOCIALIST
REPUBLIC OF SRI LANKA**

MINISTRY OF

NATIONAL WATER SUPPLY AND DRAINAGE BOARD

**SUPPLY AND DELIVERY OF VOLUMETRIC
DISPLACEMENT TYPE
.....mm DOMESTIC WATER METERS & SPARE PARTS**

CONTRACT No.:

REVISED ON 17-01-2024

**NATIONAL WATER SUPPLY AND DRAINAGE BOARD
GALLE ROAD
RATMALANA
SRI LANKA**

**.....
MONTH & YEAR**

DOCUMENT ISSUANCE CERTIFICATE

(To be filled at the time of issue by the authorised issuing officer)

1. STANDARD SPECIMEN DOCUMENT NUMBER: NWSDB/SBD/SUP/Water Meter/FC/Ver 1
2. CONTRACT NUMBER:
- 3 a) ISSUED TO :
.....
- b) ADDRESS:
.....
- c) TELEPHONE NUMBER:
- d) FACSIMILE NUMBER:
4. a) TENDER FEE : Rs. RECEIVED IN CASH/ BANK DRAFT
- b) COURIER FEE: Rs.
- c) RECEIPT/BANK DRAFT NUMBER:
5. NUMBER OF COPIES ISSUED :
6. NUMBER OF CANCELLED COPIES ISSUED :
7. CANCELLED COPY FEE : Rs..... RECEIVED/NOT RECEIVED
(IN CASH/BANK DRAFT)
8. a) ISSUING OFFICER :
- b) DESIGNATION :
- c) SIGNATURE :
9. PLACE OF ISSUE :
10. SEAL :
11. DATE : TIME :

TABLE OF CONTENTS

SECTION	<u>PAGE NUMBER</u>	
	From	To
Document Issuance Certificate		(i)
Table of Contents	(ii)	(iv)
Check List of submissions		(v)
Invitation for Bid		(vi)
1. Instructions to Bidders	1 – 1	1 - 23
2. General Conditions of Contract	2 – 1	2 - 24
3. Form of Bid	3 -1	3 -2
4. Bidding Data	4 –1	4- 3
5. Contract Data	5 -1	5 – 3
5.1 General		5 - 1
5.2 Delivery Schedule		5 - 2
5.3 Payment Schedule		5 - 3
6. Specification	6s – 1	6s – 16
7. Schedule of Particulars	7 -1	7– 9
8. Deviation from Specifications		8 - 1
9. Bills of Quantities		
9.1 Preamble Notes on Pricing	9 - 1	9 - 2
9.2 Bills of Quantities		9 - 5
9.3 Summary of Bills	9 – 6	9 - 7
10. Specimen Forms	10 – 1	10 – 8
10.1 Bid Security		10 - 1
10.2 Contract Agreement	10 – 2	10 – 5
10.3 Performance Security		10 - 6
10.5 Letter of Acceptance	10 - 7	10 - 8

11	Appendices	
	• Appendix 1 - Details of similar manufactures completed within the last five years and ongoing	11 - 1
	• Appendix 2 - Financial statement	11 - 2
	• Appendix 2 A - Authorization for Bank References	11 - 3
	• Appendix 3 - Letter for Conformation of capability of Production and Supply according to Delivery Schedule	11 - 4
	• Appendix 4 - Manufacturer's Authorization to Sign The Contract	11 - 5
	• Appendix 5 - Bidder's Authorization to Sign the Contract	11 - 6
	• Appendix 6 - TOR for the Independent Inspection Agency	11 - 7
	• Appendix 7 - Manufacturer's Awareness of the TOR for Independent Inspection Agency	11 - 8
	• Appendix 8 - Manufacturer's Warranty for the Goods (Supplied Under the Contract)	11 - 9
	• Appendix 9 - Manufacturer's Guarantee for the Replacement of unacceptable Goods Supplied under the Contract	11 - 10
	• Appendix 10 - Format for Bidder's Test Certificates	11 - 11 11 - 32
	• Appendix (A) - Meter Size and Overall dimension (diagram)	11 - 11
	• Appendix (B) – Water Meter Dimensions (Table 1)	11 - 12
	• Appendix (C) – Sample size code letters (Table 1)	11 - 13
	• Appendix (D) –Details referred to in conditions of contract	11 - 14

• Appendix (E)- Single sampling plans for normal Inspection (Master Table)	11 - 15	
• Appendix (F) - Factory Inspection/ Audit Report	11 - 16	11 - 28
• Appendix (G) - In Process Inspection Certificate (During Production Inspection)	11 - 29	11 - 30
• Appendix (H) - Pre-Production Certificate		11 - 31
• Appendix (I) - Quality Control/ Assurance System Certificate		11 - 32
• Appendix 11 - Confirmation of supplying goods manufactured at the factory quoted		11 - 33
• Appendix 12 - Affidavit by the Bidder		11 - 34
• Appendix 13 - Letter for Conformation of Issuing Certificate Accredited Lab/ Independent Inspection Agency on proper Functioning of the Water Meters.		11 - 35
• Appendix 14 - Sample of Pre- Shipment Test Certificate	11 - 36	11 - 40
• Appendix 15 - Sample of Endurance Test Certificate	11 - 41	11 - 45
• Appendix 16 – Entitle Allowances on Foreign Travels & related Expenses		11 - 46

CHECKLIST OF SUBMISSIONS

CHECKLIST OF SUBMISSIONS

- **Note: Please mark 'Y' in the cages under the "remarks" column if submissions are made. 'N' or 'N/A' should be marked for cases of 'No submissions' and 'not applicable' respectively.**

		Reference		Remark*
		Page No.	Clause No.	
(a)	Quality Assurance Certificates for items offered/Bidder.	Page No. 1 - 4	Clause No. 2.1 (b)	
(b)	Certified copy of business registration	Page No. 1 - 4 1 - 5	Clause No. 2.1 (d)	
(c)	Documentary evidence to establish eligibility of Bidding.	Page No. 1 – 4, 1- 5	Clause No. 2.1	
(d)	Number of samples meters of volumetric type complete with end connections and washers	Page No. 1- 5	Clause No. 2.1	
(e)	Documentary evidence to establish qualifications for the performance of the Contract	Page No. 1 - 5, & 1-6	Clause No.2.2	
(f)	The Bidder's technical and production capability necessary to perform the Contract	Page No. 1 – 6	Clause No. 2.2 (b)	
(g)	In the case of a Bidder offering to supply components under the Contract which the Bidder does not manufacture or otherwise produce, authorization by the manufacturer or producer of Goods as his accredited agent.	Page No. 1 - 6	Clause No. 2.2 (b)	
(h)	The agreement of the Bidder to confirm that the supply will be made in accordance with the Delivery Schedule.	Page No. 1 - 6	Clause No. 2.2 (b)	
(i)	Documentary evidence to establish that goods offered are from an eligible source and origin	Page No. 1 - 6	Clause No.3	
(j)	Certified copy of factory audited report	Page No. 1 - 6	Clause No. 2.2 (b)	
(k)	Certified copy of Product Catalogue	Page No. 1 - 6	Clause No. 2.2 (b)	
(l)	End user certificate for the successful performance of the supplied meters.	Page No. 4 – 1	Clause No. 2.2 (c)	
(m)	Quality Assurance Documents	Page No. 1-8 & 1 - 9	Clause No.10.1	
(n)	Subsequent Addendum/Addenda (if any)	Page No. 1 - 9	Clause No. 8	
(o)	Duly completed section 1 to 11 of Bidding Documents. (Bidder shall fill the Schedule of Particulars, BOQ etc., indicating any deviations to specifications under the corresponding schedule of particulars)	Page No. 1– 9	Clause No. 10.1 (a)	
(p)	Product Conformity Certificates	Page No. 1 - 10	Clause No. 10.3	
(q)	Certified copy of the VAT registration certificate.	Page No. 1 - 11	Clause No. 11.5	
(r)	Bid Security	Page No. 1 - 13	Clause No. 13	
(s)	Proof of Authorisation	Page No. 1 - 14	Clause No. 15.3	
(t)	Certificates of registration of the contract with the registrar of public contracts as per the Act No. 3 of 1987.	Page No. 1-23	Clause No. 38	
Any other document as given below:				

INVITATION FOR BIDS

MINISTRY OF

NATIONAL WATER SUPPLY AND DRAINAGE BOARD

INVITATION FOR BIDS

SUPPLY AND DELIVERY OF VOLUMETRIC DISPLACEMENT TYPE

.....mm DOMESTIC WATER METERS & SPARE PARTS

CONTRACT No.:

1. The Chairman, Standing Cabinet Appointed Procurement Committee, Ministry of, No.35, "Lakdiya Medura", New Parliament Road, Pelawatta, Battaramulla, Sri Lanka, on behalf of the National Water Supply & Drainage Board now invites sealed bids for the supply and delivery of Volumetric displacement typemm domestic water meters & spare parts for Water Supply Scheme up to closing bids at hours on
2. Bidding Documents are available at the office of the Assistant General Manager (Tenders and Contracts), National Water Supply & Drainage Board (NWSDB), Galle Road, Ratmalana, Sri Lanka between 09:00 hours to 15:00 hours on normal working days up to, upon payment of a non refundable fee of Rs.plus applicable VAT.
3. Bidding Documents may be inspected free of charge at the office of the Assistant General Manager (Tenders and Contracts), NWSDB, Galle Road, Ratmalana, Sri Lanka.
4. Bidding Documents will be issued only to those who submit a written application on the bidder's official letter head to the address indicated in the bid notice and a proof of payment of the non-refundable document fee as specified in the Bid notice.
5. To be eligible for contract award, the successful bidder shall not have been blacklisted.
6. Alternative bids shall not be accepted.
7. Sealed bids may be either dispatched by registered post or hand delivered to the Chairman, Standing Cabinet Appointed Procurement Committee, Procurement Division, Ministry of, No. 35, "Lakdiya Madura", New Parliament Road, Pelawatta, Battaramulla, Sri Lanka to receive on or before the closing time. Late bids will be rejected.
8. This Bidding Documents consists of two (02) bills and Bidder shall bid for all two (02) bills. Two bills will be evaluated separately and the employer shall have right to award the single bill or both bills.
9. a). All Bids shall be accompanied by a bid security of Rupees and bid security shall be valid up to.....(*Specify the Date*).
b). A receipt of payment of Rs..... as sample testing chargers to NWSDB shall be submitted with sample.
10. Bids will be opened immediately after the closing of Bids, at the office of the Procurement Division, Ministry of, No.35, "Lakdiya Medura", New Parliament Road, Pelawatta, Battaramulla, Sri Lanka. Bidders or their authorised representatives may be present at the opening of bids.
11. For further details, please contact the Assistant General Manager (Tenders and Contracts), NWSDB, Galle Road, Ratmalana, Sri Lanka on telephone number 94 -11-2605328 or 94-11-2638999 Ext. 1750 or facsimile number 94 -11-2635885.

Chairman

NATIONAL WATER SUPPLY AND DRAINAGE BOARD

MINISTRY OF
NATIONAL WATER SUPPLY AND DRAINAGE BOARD
INVITATION FOR BIDS
SUPPLY AND DELIVERY OF VOLUMETRIC DISPLACEMENT TYPE
.....mm DOMESTIC WATER METERS & SPARE PARTS

CONTRACT No.:

1. The Chairman, Ministry Procurement Committee, Ministry of,
....., No.35, “Lakdiya Medura”, New Parliament Road, Pelawatta, Battaramulla, Sri Lanka, on behalf of the National Water Supply & Drainage Board now invites sealed bids for the supply and delivery of Volumetric displacement typemm domestic water meters & spare parts for Water Supply Scheme up to closing of bids at hours on
2. Bidding Documents are available at the office of the Assistant General Manager (Tenders and Contracts), National Water Supply & Drainage Board (NWSDB), Galle Road, Ratmalana, Sri Lanka, between 09:00 hours to 15:00 hours on normal working days up to, upon payment of a non refundable fee of Rs.plus applicable VAT.
3. Bidding Documents may be inspected free of charge at the office of the Assistant General Manager (Tenders and Contracts), NWSDB, Galle Road, Ratmalana, Sri Lanka.
4. Bidding Documents will be issued only to those who submit a written application on the bidder’s official letter head to the address indicated in the bid notice and a proof of payment of the non-refundable document fee as specified in the Bid notice.
5. To be eligible for contract award, the successful bidder shall not have been blacklisted.
6. Alternative bids shall not be accepted.
7. Sealed bids may be either dispatched by registered post or hand delivered to the Chairman, Ministry Procurement Committee, Procurement Division, Ministry of
....., No. 35, “Lakdiya Madura”, New Parliament Road, Pelawatta, Battaramulla, Sri Lanka to receive on or before the closing time. Late bids will be rejected.
8. This Bidding Documents consists of two (02) bills and Bidder shall bid for all two (02) bills. Two bills will be evaluated seperatly and the employer shall have right to award the single bill or both bills.
9. a). All Bids shall be accompanied by a bid security of Rupees and bid security shall be valid up to.....(*Specify the Date*).
b). A receipt of payment of Rs..... as sample testing chargers to NWSDB shall be submitted with sample.
10. Bids will be opened immediately after the closing of Bids, at the office of the Procurement Division, Ministry of, No.35, “Lakdiya Medura”, New Parliament Road, Pelawatta, Battaramulla, Sri Lanka. Bidders or their authorised representatives may be present at the opening of bids.
11. For further details, please contact the Assistant General Manager (Tenders and Contracts), NWSDB, Galle Road, Ratmalana, Sri Lanka on telephone number 94 -11-2605328 or 94-11-2638999 Ext. 1750 or facsimile number 94 -11-2635885.

Chairman
NATIONAL WATER SUPPLY AND DRAINAGE BOARD

MINISTRY OF
NATIONAL WATER SUPPLY AND DRAINAGE BOARD
INVITATION FOR BIDS
SUPPLY AND DELIVERY OF VOLUMETRIC DISPLACEMENT TYPE
.....mm DOMESTIC WATER METERS & SPARE PARTS

CONTRACT No.:

1. The Chairman, Department Procurement Committee, National Water Supply and Drainage Board (NWSDB), Galle Road, Ratmalana, Sri Lanka, on behalf of the National Water Supply & Drainage Board now invites sealed bids for the Supply and Delivery of Volumetric Displacement Type.....mm Domestic Water Meters & Spare Parts up to closing of bids at hours on
2. Bidding Documents are available at the office of the Assistant General Manager (Tenders and Contracts), National Water Supply & Drainage Board (NWSDB), Galle Road, Ratmalana, Sri Lanka, between 09:00 hours to 15:00 hours on normal working days up to, upon payment of a non refundable fee of Rs./= plus applicable VAT.
3. Bidding Documents may be inspected free of charge at the office of the Assistant General Manager (Tenders and Contracts), NWSDB, Galle Road, Ratmalana, Sri Lanka.
4. Bidding Documents will be issued only to those who submit a written application on the bidder's official letter head to the address indicated in the bid notice and a proof of payment of the non-refundable document fee as specified in the Bid notice.
5. To be eligible for contract award, the successful bidder shall not have been blacklisted.
6. Alternative bids shall not be accepted.
7. Sealed bids may be either dispatched by registered post or hand delivered to the office of Assistant General Manager (Tenders and Contracts), NWSDB, Galle Road, Ratmalana, Sri Lanka to receive on or before the closing time. Late bids will be rejected.
8. This Bidding Documents consists of two (02) bills and Bidder shall bid for all two (02) bills. Two bills will be evaluated separately and the employer shall have right to award the single bill or both bills.
9. a). All Bids shall be accompanied by a bid security of Rupees and bid security shall be valid up to.....(*Specify the Date*).
b). A receipt of payment of Rs..... as sample testing chargers to NWSDB shall be submitted with sample.
10. Bids will be opened immediately after the closing of Bids, at the office of the Assistant General Manager (Tenders and Contracts), NWSDB, Galle Road, Ratmalana, Sri Lanka. Bidders or their authorized representatives may be present at the opening of bids.
11. For further details, please contact the Assistant General Manager (Tenders and Contracts), NWSDB, Galle Road, Ratmalana, Sri Lanka on telephone number 94 -11-2605328 or 94-11-2638999 Ext. 1750 or facsimile number 94 -11-2635885.

Chairman,
NATIONAL WATER SUPPLY AND DRAINAGE BOARD

1. INSTRUCTION TO BIDDERS

2. GENERAL CONDITION OF CONTRACT

3. FORM OF BID

THE GOVERNMENT OF THE DEMOCRATIC SOCIALIST REPUBLIC OF SRI LANKA

MINISTRY OF

NATIONAL WATER SUPPLY AND DRAINAGE BOARD

**SUPPLY AND DELIVERY OF VOLUMETRIC DISPLACEMENT TYPE
.....mm DOMESTIC WATER METERS & SPARE PARTS**

CONTRACT No.:

FORM OF BID

The Chairman,
Standing Cabinet Appointed Procurement Committee,
Ministry of,
No. 35, "Lakdiya Medura"
New Parliament Road,
Pelawatta,
Battaramulla.

I/We, the undersigned, having authority to sign this Bid and having read and fully acquainted myself/ourselves with the contents of the Information and Instructions to Bidders and Terms and Conditions of Bid and Delivery Schedule pertaining to the above Bid, along with Bills thereto, do hereby undertake to supply the Goods and Services referred to therein, in accordance with the aforesaid Instructions, Terms and Conditions for a total Bid price of foreign currency in United States Dollars (US\$)..... (in words) US \$.....(in figures) and Sri Lanka Rupees..... (in words) Rs.....(in figures) (excluding VAT) The make up of the aforesaid total Bid Price is given in the accompanying Bills of Quantities.

I/We confirm that this offer shall be open for acceptance until as given in the Bidding Data and that it will not be withdrawn or revoked prior to that date.

I/We attach hereto the following documents as part of my/our Bid.

1. Duly completed sections 1 to 11 of Bid Documents.
2. Documentary evidence to establish eligibility of Bidder.
3. Documentary evidence to Establish qualification to consider for the responsiveness to the contract.
4. Documentary evidence to establish that goods are offered from an eligible source and origin.
5. Documentary evidence to establish eligibility of goods offered.
6. Bid Security
7. Documentary evidence to establish qualifications for the performance of the Contract.
8. Bidding Data
9. Duly filled Appendices.
10. Any other document.

I/We declare that the photostat copies of documents and certificates submitted as part of my/our Bid are true copies of such documents and certificates. Also in case of ISO 9001:2015 certificate(s), and Product conformity certificate (s) as listed in the specifications I/we confirm that I/we have verified that the certificate issuing authority has accreditation to issue same and materials offered conform to the ISO 9001 :2015 certificates and the specified product standard certificates.

I/We further agree to the right of the Board to debar me/us from participating in its future Bids in the event that my/our submitted copies or documents are found to be forged or tampered with.

I/We understand that you are not bound to accept the lowest Bid and that you reserve the right to reject any or all Bids or to accept any part of a Bid without assigning any reasons thereto.

I/We undertake to adhere to the Delivery Schedule given in the Contract Data.

My/Our Bank Reference is as follows:
.....

Signature of Bidder :
Name of Bidder :
Address :
Capacity :
Telephone Number :
Facsimile Number :
Date :

Witnesses

1. Signature :
Name :-
Address :
Capacity :
2. Signature :
Name :-
Address :
Capacity :

THE GOVERNMENT OF THE DEMOCRATIC SOCIALIST REPUBLIC OF SRI LANKA

MINISTRY

NATIONAL WATER SUPPLY AND DRAINAGE BOARD

SUPPLY AND DELIVERY OF VOLUMETRIC DISPLACEMENT TYPE

.....mm DOMESTIC WATER METERS & SPARE PARTS

CONTRACT No.:

FORM OF BID

The Chairman,
Ministry Procurement Committee,
Ministry of,
No. 35, "Lakdiya Medura"
New Parliament Road,
Pelawatta,
Battaramulla.

I/We, the undersigned, having authority to sign this Bid and having read and fully acquainted myself/ourselves with the contents of the Information and Instructions to Bidders and Terms and Conditions of Bid and Delivery Schedule pertaining to the above Bid, along with Bills thereto, do hereby undertake to supply the Goods and Services referred to therein, in accordance with the aforesaid Instructions, Terms and Conditions for a total Bid price of foreign currency in United States Dollars (US\$).....(*in words*)
US \$.....(*in figures*) and Sri Lanka Rupees

.....
(*in words*) Rs.(*in figures*) (excluding VAT) The make up of the aforesaid total Bid Price is given in the accompanying Bills of Quantities.

I/We confirm that this offer shall be open for acceptance until as given in the Bidding Data and that it will not be withdrawn or revoked prior to that date.

I/We attach hereto the following documents as part of my/our Bid.

1. Duly completed sections 1 to 11 of Bid Documents.
2. Documentary evidence to establish eligibility of Bidder.
3. Documentary evidence to Establish qualification to consider for the responsiveness to the contract.
4. Documentary evidence to establish that goods are offered from an eligible source and origin.
5. Documentary evidence to establish eligibility of goods offered.
6. Bid Security
7. Documentary evidence to establish qualifications for the performance of the Contract.
8. Bidding Data
9. Duly filled Appendices.
10. Any other document.

I/We declare that the photostat copies of documents and certificates submitted as part of my/our Bid are true copies of such documents and certificates. Also in case of ISO 9001:2015 certificate(s), and Product conformity certificate (s) as listed in the specifications I/we confirm that I/we have verified that the certificate issuing authority has accreditation to issue same and materials offered conform to the ISO 9001 : 2015 certificates and the specified product standard certificates.

I/We further agree to the right of the Board to debar me/us from participating in its future Bids in the event that my/our submitted copies or documents are found to be forged or tampered with.

I/We understand that you are not bound to accept the lowest Bid and that you reserve the right to reject any or all Bids or to accept any part of a Bid without assigning any reasons thereto.

I/We undertake to adhere to the Delivery Schedule given in the Contract Data.

My/Our Bank Reference is as follows:

.....

Signature of Bidder :

Name of Bidder :

Address :

Capacity :

Telephone Number :

Facsimile Number :

Date :

Witnesses

1. Signature :

Name :-

Address :

Capacity :

2. Signature :

Name :-

Address :

Capacity :

THE GOVERNMENT OF THE DEMOCRATIC SOCIALIST REPUBLIC OF SRI LANKA

MINISTRY OF

NATIONAL WATER SUPPLY AND DRAINAGE BOARD

SUPPLY AND DELIVERY OF VOLUMETRIC DISPLACEMENT TYPE

.....mm DOMESTIC WATER METERS & SPARE PARTS

CONTRACT No.:

FORM OF BID

The Chairman,
Department of Procurement Committee,
National Water Supply & Drainage Board,
Galle Road,
Ratmalana,
Sri Lanka.

I/We, the undersigned, having authority to sign this Bid and having read and fully acquainted myself/ourselves with the contents of the Information and Instructions to Bidders and Terms and Conditions of Bid and Delivery Schedule pertaining to the above Bid, along with Bills thereto, do hereby undertake to supply the Goods and Services referred to therein, in accordance with the aforesaid Instructions, Terms and Conditions for a total Bid price of foreign currency in United States Dollars (US\$).....(in words)
US \$.....(in figures) and Sri Lanka Rupees

.....
(in words) RS.(in figures) (excluding VAT) The make up of the aforesaid total Bid Price is given in the accompanying Bills of Quantities.

I/We confirm that this offer shall be open for acceptance until as given in the Bidding Data and that it will not be withdrawn or revoked prior to that date.

I/We attach hereto the following documents as part of my/our Bid.

1. Duly completed sections 1 to 11 of Bid Documents.
2. Documentary evidence to establish eligibility of Bidder.
3. Documentary evidence to Establish qualification to consider for the responsiveness to the contract.
4. Documentary evidence to establish that goods are offered from an eligible source and origin.
5. Documentary evidence to establish eligibility of goods offered.
6. Bid Security
7. Documentary evidence to establish qualifications for the performance of the Contract.
8. Bidding Data.
9. Duly filled Appendices.
10. Any other document.

I/We declare that the photostat copies of documents and certificates submitted as part of my/our Bid are true copies of such documents and certificates. Also in case of ISO 9001:2015 certificate(s), and Product Conformity Certificate (s) as listed in the specifications I/we confirm that I/we have verified that the certificate issuing authority has accreditation to issue same and materials offered conform to the ISO 9001 : 2015 certificates and the specified Product Conformity Certificates and other Certificates specified.

I/We further agree to the right of the Board to debar me/us from participating in its future Bids in the event that my/our submitted copies or documents are found to be forged or tampered with.

I/We understand that you are not bound to accept the lowest Bid and that you reserve the right to reject any or all Bids or to accept any part of a Bid without assigning any reasons thereto.

I/We undertake to adhere to the Delivery Schedule given in the Contract Data.

My/Our Bank Reference is as follows:
.....

Signature of Bidder :

Name of Bidder :

Address :

Capacity :

Telephone Number :

Facsimile Number :

Date :

Witnesses

1. Signature :

Name :-

Address :

Capacity :

2. Signature :

Name :-

Address :

Capacity :

4. BIDDING DATA

The Bidding Data is a part of Instructions to Bidders and should be read in conjunction with the Instructions to Bidders.

If there is a discrepancy found in the Instructions to Bidders and the Bidding Data, the Content in the Bidding Data shall supersede the Content in the Instructions to Bidders of This Document.

(Note: What is typed in italic letters are guide lines to prepare the Bidding Data and they shall be removed after preparation of the Bidding Data.)

BIDDING DATA

(Please note that the Clause numbers given here under are that of Instruction to Bidder.)

**Clause Reference Number
Instructions to Bidders**

1.1 The Supplier is expected to supply the following items of materials

.....
.....

2.1(j) Submission of Samples

Every bidder shall submit 07 (seven) samples of water meters ofmm volumetric displacement type complete with end connections and washers for inspection and testing by National Water Supply & Drainage Board.

Every bidder shall submit 02 (two) samples of spare parts of above for inspection and testing by National Water Supply & Drainage Board.

All samples shall be well packed in a suitable plastic box, sealed and labeled to facilitate identification.

The samples shall truly represent the meters and spare parts offered to be supplied under this contract in every aspect. No samples will be returned and the cost of providing samples shall be borne by the tenderers.

2.2. Qualification

(a)(i)

- For water meters

The Manufacturer shall have manufactured and supplied an average annual production of minimum 500,000 nos, mm diameter (*similar diameter*) during last five years out of whichnos. (*similar quantities*) shall be from countries with tropical conditions similar to Sri Lanka.

- For spare parts of water meters

The Manufacturer shall have manufactured and supplied an average annual production of minimum 500,000 nos, mm diameter (*similar diameter*) spare parts during last five years out of whichnos. (*similar quantities*) shall be from countries with tropical conditions similar to Sri Lanka.

(Documentary evidence to justify shall be submitted)

2.2 (b)

(i) **Bidder's Financial Capacity**

Working Capital *1 + present available credit facilities for the company*2 + credit facilities exclusively for this contract - 0.1 x current work commitments*3 > Rs.....*4

*1 Working Capital = Current Assets – Current Liabilities.

*2 A letter to prove the availability of credit facilities issued by a Bank within a month prior to date of closing of Bids.

*3 current work commitment = work remaining uncompleted.
(Documentary evidence to justify shall be submitted)

*4 15% of estimated cost of the Bid for both bills.

2.2 (c) End user Certificates

Certificates of performance shall be obtained from end users of countries other than the manufacturing country and forwarded along with the offer.

Such end users should have purchased No. of lots each of which consisting of more than meters, during the last 05 years.

End user certificates shall contain,

- i. Name of the end user
- ii. Name of the contact person
- iii. Phone number, fax No., e-mail address, web address, etc.
- iv. Mail address
- v. Name of relevant project/local authority/water authority etc.
- vi. Description of the purchases made
- vii. Dates purchased
- viii. Full details of performance of relevant meters i.e. performance within the specifications, durability, lifetime etc.

Offers not accompanying these certificates shall be considered as substantially non-responsive.

(4) Funds required for this contract is available under

(6.2) The address for the purchase of Bidding Document/clarification of Bidding Document is

Assistant General Manager (Tenders & Contracts),
National Water Supply & Drainage Board (NWSDB),
Galle Road, Ratmalana.
FAX 94 -11 – 2635885 TEL. 94 - 11-2605328

(13.2) The amount of Bid Security shall be.....Sri Lankan Rupees.

(13.3) The validity of Bid Security shall be up to (specify the date)

(14.1) The period of Bid Validity shall be 210 Days from the date of closing of Bid.

(17.2) (a) The inner and outer envelopes shall be addressed as follows:
The Chairman, Standing Cabinet Appointed Procurement Committee,
Procurement Division,
Ministry of
No. 35, “Lakdiya Medura”
New Parliament Road, Pelawatta, Battaramulla
Sri Lanka.

(c) “Not to be opened before(Time) on (Date)”

(18.1) The Procurement Committee’s address for the purpose of Bid submission (and on behalf of the Board) and Bid opening is;

Standing Cabinet Appointed Procurement Committee,
Procurement Division,
Ministry of
No. 35, “Lakdiya Medura”
New Parliament Road, Pelawatta, Battaramulla
Sri Lanka

The deadline for submission of Bid

Date:.....

Time:

(21.1) The place for opening of bids,

Standing Cabinet Appointed Procurement Committee,
Procurement Division,
Ministry of
No. 35, “Lakdiya Medura”
New Parliament Road,
Pelawatta, Battaramulla,
Sri Lanka.

(24.1) Add to Clause

If a Bid does not meet any one of the requirements (a), (b), & (c) of **Clause 24.1**, it Will be considered substantially non responsive and rejected by the Procurement Committee.

(24.4) The bidding document consist of two bills and bidder shall bid for all two (02) bills. Two bills will be evaluated and employer shall have right to avoid the single bill or both bills.

(27.2) Add to Clause

The evaluation and comparison of bids will be carried out bill wise.

(28.1) After evaluation of Bids in accordance with the procedures described under **Clauses 23, 24, 25, 26, 27 and 28**, the Employer will inform to all the bidders in writing the selection of the successful bidder and the intention of contract award to such bidder. The unsuccessful bidders if they so wish, within one week of such notice may make representation to the Procurement Appeal Board at the address given below. Such representation shall be self-contained to enable the Appeal Board to arrive at a conclusion and a cash deposit to amount given below shall be made. The Appeal Board may request the bidder who had made representation to submit further evidence during the investigations. The cash deposit will be forfeited unless the Employer change the original contract award decision in favour of the bidder who has made such representation.

Address : The Secretary
 Appeal Board, Presidential Secretariat,
 Colombo, Sri Lanka.

Cash Deposit: Rupees 100,000.00

(32.2) The prevailing rate of stamp duty on contracts for supply of goods is nil.

(34.1) The amount of Performance Guarantee shall be 10% of the Contract Price.

BIDDING DATA

(Please note that the Clause numbers given here under are that of Instruction to Bidder.)

Clause Reference Number
Instructions to Bidders

1.1 The Supplier is expected to supply the following items of materials

.....
.....

2.1(j) Submission of Samples

Every bidder shall submit 07 (seven) samples of water meters ofmm volumetric type complete with end connections and washers for inspection and testing by National Water Supply & Drainage Board.

Every bidder shall submit 02 (two) samples of spare parts of above for inspection and testing by National Water Supply & Drainage Board

All samples shall be well packed in a suitable plastic box, sealed and labeled to facilitate identification.

The samples shall truly represent the meters and spare parts offered to be supplied under this contract in every aspect. No samples will be returned and the cost of providing samples shall be borne by the tenderers.

2.2. Qualification

2.2 (a) (i)

- For water meters

The Manufacturer shall have manufactured and supplied an average annual production of minimum 500,000 nos, mm diameter (*similar diameter*) during last five years out of whichnos. (*similar quantities*) shall be from countries with tropical conditions similar to Sri Lanka.

- For spare parts of water meters

The Manufacturer shall have manufactured and supplied an average annual production of minimum 500,000 nos, mm diameter (*similar diameter*) spare parts during last five years out of whichnos. (*similar quantities*) shall be from countries with tropical conditions similar to Sri Lanka.

(Documentary evidence to justify shall be submitted)

(17.2) (a) The inner and outer envelopes shall be addressed as follows:
The Chairman, Ministry Procurement Committee,
Procurement Division,
Ministry of,
No. 35, “Lakdiya Medura”
New Parliament Road,
Pelawatta, Battaramulla,
Sri Lanka.

(c) “Not to be opened before(Time) on (Date)”

(18.1) The Procurement Committee’s address for the purpose of Bid submission (and on behalf of the Board) and Bid opening is;

The Chairman, Ministry Procurement Committee,
Procurement Division,
Ministry of,
No. 35, “Lakdiya Medura”, New Parliament Road,
Pelawatta, Battaramulla,
Sri Lanka.

The deadline for submission of Bid

Date:.....

Time:

(21.1) The place for opening of Bids,

Ministry Procurement Committee,
Procurement Division,
Ministry of,
No. 35, “Lakdiya Medura”
New Parliament Road,
Pelawatta,
Battaramulla,
Sri Lanka.

(24.1) Add to Clause

If a Bid does not meet any one of the requirements (a), (b) & (c) of **Clause 24.1**, it will be considered substantially non responsive and rejected by the Procurement Committee

(24.4) The bidding document consist of two bills and bidder shall bid for all two (02) bills. Two bills will be evaluated and employer shall have right to avoid the single bill or both bills.

(27.2) Add to Clause

The evaluation and comparison of bids will be carried out bill wise.

(28.1) After evaluation of Bids in accordance with the procedures described under **Clauses 23, 24, 25, 26, 27 and 28**, the Employer will inform to all the bidders in writing the selection of the successful bidder and the intention of contract award to such bidder. The unsuccessful bidders if they so wish, within one week of such notice may make representation to the Ministry Procurement Appeal Board at the address given below.

Such representation shall be self-contained to enable the Appeal Board to arrive at a conclusion and a cash deposit to amount given below shall be made. The Appeal Board may request the bidder who had made representation to submit further evidence during the investigations. The cash deposit will be forfeited unless the Employer change the original contract award decision in favour of the bidder who has made such representation.

Address : The Secretary
Ministry Procurement Appeal Board,
Ministry of,
No. 35, "Lakdiya Medura"
New Parliament Road,
Pelawatta,
Battaramulla.

Cash Deposit: Rupees 25,000.00

(32.2) The prevailing rate of stamp duty on contracts for supply of goods is nil.

(34.1) The amount of Performance Guarantee shall be 10% of the Contract Price.

BIDDING DATA

(Please note that the Clause numbers given here under are that of Instruction to Bidder.)

Clause Reference Number

Instructions to Bidders

1.1 The Supplier is expected to supply the following items of materials
.....
.....

2.1(j) Submission of Samples

Every bidder shall submit 07 (seven) samples of water meters ofmm volumetric type complete with end connections and washers for inspection and testing by National Water Supply & Drainage Board.

Every bidder shall submit 02 (two) samples of spare parts of above for inspection and testing by National Water Supply & Drainage Board

All samples shall be well packed in a suitable plastic box, sealed and labeled to facilitate identification.

The samples shall truly represent the meters and spare parts offered to be supplied under this contract in every aspect. No samples will be returned and the cost of providing samples shall be borne by the tenderers.

2.2. Qualification

2.2 (a) (i)

- For water meters

The Manufacturer shall have manufactured and supplied an average annual production of minimum 500,000 nos, mm diameter (*similar diameter*) during last five years out of whichnos. (*similar quantities*) shall be from countries with tropical conditions similar to Sri Lanka.

- For spare parts of water meters

The Manufacturer shall have manufactured and supplied an average annual production of minimum 500,000 nos, mm diameter (*similar diameter*) spare parts during last five years out of whichnos. (*similar quantities*) shall be from countries with tropical conditions similar to Sri Lanka.

(Documentary evidence to justify shall be submitted).

2.2 (b) (i) **Bidder's Financial Capacity**

Working Capital ^{*1} + present available credit facilities for the company^{*2} + credit facilities exclusively for this contract - 0.1 x current work commitments^{*3} > Rs.....^{*4}

- *1 Working Capital = Current Assets – Current Liabilities.
- *2 A letter to prove the availability of credit facilities issued by a Bank within a month prior to date of closing of Bids.
- *3 current work commitment = work remaining uncompleted.
(Documentary evidence to justify shall be submitted)
- *4 15% of estimated cost of the Bid.

2.2 (c) End user Certificates

Certificates of performance shall be obtained from end users of countries other than the manufacturing country and forwarded along with the offer.

Such end users should have purchased No. of lots each of which consisting of more than meters, during the last 05 years.

End user certificates shall contain,

- i. Name of the end user
- ii. Name of the contact person
- iii. Phone number, fax No., e-mail address, web address, etc.
- iv. Mail address
- v. Name of relevant project/local authority/water authority etc.
- vi. Description of the purchases made
- vii. Dates purchased
- viii. Full details of performance of relevant meters i.e. performance within the specifications, durability, lifetime etc.

Offers not accompanying these certificates shall be considered as substantially non-responsive.

(4) Funds required for this contract is available under

(6.2) The address for the purchase of Bidding Document/clarification of Bidding Document is

Assistant General Manager (Tenders & Contracts),
National Water Supply & Drainage Board (NWSDB),
Galle Road, Ratmalana.
FAX 011 – 2635885 TEL. 011-2605328

(13.2) The amount of Bid Security shall be.....Sri Lankan Rupees.

(13.3) The validity of Bid Security shall be up to (*specify the date*).

(14.1) The period of Bid Validity shall be 91 Days from the date of closing of Bid.

- (17.2) (a) The inner and outer envelopes shall be addressed as follows:
The Chairman, Department Procurement Committee,
C/o, Assistant General Manager (Tenders & Contracts),
National Water Supply and Drainage Board,
Galle Road, Ratmalana, Sri Lanka.
- c) “Not to be opened before(Time) on (Date)”
- (18.1) The Procurement Committee’s address for the purpose of Bid submission (and on behalf of the Board) and Bid opening is;
Department Procurement Committee,
Assistant General Manager (Tenders & Contracts Section),
National Water Supply and Drainage Board,
Galle Road, Ratmalana,
Sri Lanka.
- The deadline for submission of Bid
Date:..... Time:
- (21.1) The place for opening of Bids,
Department Procurement Committee,
C/o, Assistant General Manager (Tenders & Contracts),
Tenders & Contract Branch,
National Water Supply and Drainage Board,
Galle Road,
Ratmalana, Sri Lanka
- (24.4) The bidding document consist of two bills and bidder shall bid for all two (02) bills. Two bills will be evaluated and employer shall have right to avoid the single bill or both bills.
- (27.2) Add to Clause
The evaluation and comparison of bids will be carried out bill wise.
- (33.2) The prevailing rate of stamp duty on contracts for supply of goods is nil.
- (34.1) The amount of Performance Guarantee shall be 10% of the Contract Price.

5 CONTRACT DATA

- **GENERAL**
- **DELIVERY SCHEDULE**
- **PAYMENT SCHEDULE**

The Contract Data is a part of Conditions of Contract and should be read in conjunction with the General Conditions of Contract.

If there is a discrepancy found in the General Conditions of Contract and the Contract Data, the Content in the Contract Data shall supersede the Content in the General Conditions of Contract.

(Note: What is given in italic letters are guide lines to prepare the Contract Data and they shall be removed offer preparation of the Contract Data.)

DELIVERY SCHEDULE

Item No.	Description of Goods	Quantity	Unit	Final Destination as specified in Bidding Data <i>[insert place of Delivery]</i>	Delivery Date
					Purchaser's delivery date as per the contract
01	Bill No.1				
02	Bill No. 2				

PAYMENT SCHEDULE

Letter of Credit will be opened by the Purchaser. No Advance payment will be made.

STAGE OF PAYMENT	STAGE OF CONTRACT	DOCUMENT TO BE SUBMITTED	AMOUNT OF PAYMENT	REMARKS	
(A) Foreign Payment					
1	First installment	On shipping the items part or fully.	<ul style="list-style-type: none"> ◆ Copies of the Supplier's invoice showing description of Goods, quantity, unit price, total amount and HS Code Number. ◆ 3 copies of clean on-board bill of lading marked freight prepaid. ◆ Copies of packing list identifying contents of each package and measurements. ◆ Manufacturer's warranty certificate as per Clause 15 hereof. ◆ Inspection certificates, issued by the Accredited Lab/ Independent inspection agency. ◆ Manufacturer's Inspection and Test Certificate. ◆ Certificate of origin. ◆ Certificate of conformity to the standards specified in the specifications. ◆ Inspection and test certificate by the NWSDB pre-shipment Inspection team. 	75% of foreign component of the items shipped on Letter of Credit.	
2	Balance foreign component	Final acceptance by the Engineer based on the delivery testing and passed in test performed and other obligations.	On production of a Final Acceptance Certificate issued by the Engineer. Engineer's Representative's approval for the balance payment of Foreign Component.	Balance 25% of the foreign component shall be paid.	The total Contract Sum shall become payable within <u>60 Days</u> from the date of the Engineer's Final Acceptance Certificate.
(B) Local Payment					
3	First Payment of Supply Bill.	On delivery and stacking of the Goods at site/stores, testing and passed in test performed.	Document providing the delivered Goods and tests passed in test performed are in compliance with the contract.	90% of the Local component of the Contract Price less Bank charges.	Sri Lanka Rupees component by a cheque in favour of the supplier.
4	Balance Local Payment	Final acceptance by the Engineer for the delivery and other obligations.	A written request for balance payment in the form of an invoice based on the BOQ and Engineer's approval for the payment.	10% of the Local component of the Contract Price less remaining Bank charges.	The total Contract Sum shall become payable within <u>60 Days</u> from the date of the Engineer's Final Acceptance Certificate.

7. SCHEDULE OF PARTICULARS

SCHEDULE OF PARTICULARS

NOTES

1. The Bidder shall complete the questionnaire pertaining to the materials which he offers and return it with his tender and shall give all details relevant to the materials offered.
2. All test reports specified by the Board shall be submitted at the time of delivery of materials at the stores and the supply of material shall not be considered as complete for purposes of payment until the material is tested and accepted by the Engineer.
3. The Bidder should fill in completely the Questionnaire attached herewith. The tender is liable to be rejected if the required details are not furnished.
4. The Bidders are necessarily be required to complete fully the schedule of particulars given in the bidding document for Water Meters
5. Where catalogues, technical literature and drawings accompanying the bid, their references should be quoted in the Schedule of Particulars;
6. The Bidders are necessarily be required to complete fully the schedule of particulars given in the Bidding document for Water Meters to be supplied under this contract and other fittings & accessories.
7. Where the Bidder's specification is not conforming to the minimum specification, the offer will not be accepted.

GENERAL DETAILS OF BIDDER

Company Name :

1. Head Office Address :

E Mail Address :

Telephone No.

Fax No.

2. Regional Office Address (If any) :

E Mail Address :

Telephone No.

Fax No.

3. a) Factory Address :(The factory at which offered meters are manufactured & assembled)

E Mail Address :

Telephone No.

Fax No.

b) Production Capacity

Factory	Size of meter (mm)	Annual Production Capacity (Units/Year)
	15	
	15	
	15	

c) Outsourced Factory Names & Address(in case some of the parts are outsourced from different manufactures)

Factory 1.

Name:

Address :

List of components outsourced to this factory :

- 1
- 2.
- 3.
- 4.

Web Address, e – mail, telephone, Fax and all contact details :

Factory 2.

Name :

Address :

List of components outsourced to this factory :

- 1
- 2.
- 3.
- 4.

Web Address, e – mail, telephone, Fax and all contact details :

SCHEDULE OF PARTICULARS

1. 1.1 Details of Manufacture (Product) Standard & ISO Series Certificate.

- 1. Manufacture (Product) Standard
- 2. Whether Bidder & Subcontractors posses ISO 9001:2015 certificate

Date of issue of the Total Quality Assurance certificate
Date of Expiry

1.2 No of shipments proposed by the bidder :

2 Name & Address of the Inspection Agency who issued the Quality Management System Certificates (ISO 9001:2015)

.....
.....
.....

E Mail Address :

Telephone No.

Fax No.

3 Name & Address of the Inspection Agency selected for inspection and testing of meters to be supplied under this contract.

.....
.....

E Mail Address :

Telephone No.

Fax No.

4 Name & Address of Local agent (if any) :

.....
.....

E Mail Address :

Telephone No.

Fax No.

5 Company and Year of incorporation
Main line of Business :

.....

.....

- | | |
|----|---------|
| 1. | Since : |
| 2. | Since : |
| 3. | Since : |
| 4. | Since: |

Attach copy of certificate of registration and ownership.

SCHEDULE OF PARTICULARS

No.	Meter Designation -	DN 15
1.	Make	
2.	Model	
3.	Country of Origin	
4.	Address of manufacturing factory	
5.	Addresses of outsourced factories (for component parts)	
6.	Standard to which water meters are Manufactured	
7.	Metrological Class	
8.	Body materials	
9.	Meter thread size	
10.	Length of meter	
11.	Length of meter with connectors	
12.	Thread size of end connections	
13.	Maximum working pressure a). Forward Flow b). Reverse Flow	
13.	Permanent flow rate	
14.	Starting flow	
15.	Head loss at permanent flow rate	

No.	Meter Designation	DN 15
16.	Head loss at over load flow rate	
17.	Meter reset to zero at	
18.	Minimum indicated digit value	
19.	Maximum possible working temperature without affecting the meter performance	
20.	What types of anti-tamper facility provided?	
21.	Is non return valve incorporated?	
22.	Is a strainer provided?	
23.	Are the markings & inscriptions as per Specifications	
24.	Units of registration	
25.	Is certificate of compliance attached.	
26.	Are accuracy & Head loss curves attached.	
27.	Is delivery periods as per specification	
28.	Is the information as per Clause 2.1 provided.	
29.	<ul style="list-style-type: none"> a. Name & Address of Local Agent b. Indicate facilities (After sales services availability of spare parts & workshop facilities provided by the Local Agent) 	

DETAILS OF USERS WHO HAVE PURCHASED MORE THAN 5,000 METERS

METER MANUFACTURER		
DOCUMENT EVIDENCE OF FOREIGN END USERS WHO PURCHASED LOTS OF MORE THAN 5,000 METERS DURING LAST 05 YEARS.		
1.	Name of end user	
2.	Name of contact person	
3.	Contact phone number	
4.	Fax No & E – mail address	
5.	Address	
6.	Name of project/water authority/ Local authority	
7.	Location of project/water /local authority	
8.	Number of meters purchased	
9.	Date of delivery	
10.	Date of completion	

DETAILS OF CURRENT CONTRACTS

Applicants should provide information on their current commitments on all contracts that have been awarded, or for which a letter of intent has been received, or contracts approaching completion but for which an unqualified, full completion certificate has yet to be issued.

Name & Address of Client	No. of Meters with outstanding Supply		Value in US Dollars
	Size	Quantity – Nos.	

8. DEVIATIONS FROM SPECIFICATIONS

DEVIATIONS FROM SPECIFICATIONS

Preamble

The bidder is required to list all deviations of materials, production methodology etc. from the Specification including such information as has already been given elsewhere in the bidding Documents. The information shall be in sufficient detail to enable the Purchaser to make a realistic assessment of the effect of such deviations on the performance or life of the materials to be supplied.

Deviation

9. BILLS OF QUANTITIES

- **PREAMBLE NOTES ON PRICING**
- **BILLS OF QUANTITIES**
- **SUMMARY OF BILLS**

PREAMBLE NOTES ON PRICING

1. General

1.1 The Bidder's attention is specifically directed to the Form of Bid , Instructions to Bidders, Conditions of Contract, Contract Data, Delivery Schedule, Schedule of Particulars and Specifications which are to be read in conjunction with the Bills of Quantities. The following notes are given to assist in pricing the Bills of Quantities and enable the supplier to arrive at the total Bid Price. The Bidder shall insert rates and prices for the supply and delivery of water meters and water meter spare parts in strict accordance with the specifications.

2. Description of Items

2.1 Descriptions attached to the items in the Bills of Quantities are only in sufficient detail to ensure identification of the work described in the specification.

3. Rates and prices

3.1 In pricing the items of the Bills of Quantities, the bidder shall cover himself and will be deemed to have covered himself for:

- a) All services and goods which according to the true intent and meaning of the contract may be reasonably inferred as necessary for completion of Supply & Delivery of the goods in sound condition to the Stores which is specified in **Contract Data**.
- b) All the duties, obligations, liabilities and responsibilities which the Contract documents place upon the bidders in connection with or in relation to the Contract.
- c) All costs arising out of inspection except inspection as per **Clause 8** of General Conditions of Contract, testing, packing, transportation, clearing, loading, unloading, stacking, shipping line charges, warehouse rent, any demurrages, Agents Commission if any and other minor expenses.
- d) All Costs including all taxes and duties and other charges imposed outside Sri Lanka on raw materials, production, manufacture, sales, transport and any other cost that may be incurred of all goods.
- e) All duties and taxes if any except customs duty and port charges that may be levied in purchaser's country (Sri Lanka).
- f) Cost of accessories not specifically listed, but necessary for proper completion
- g) Price charged by the supplier for the preceding incidental services.
- h) Custom duties, import license fees and port charges levied on the goods supplied under contract shall be directly paid by the Purchaser as per **Clause 32.4** of the General Conditions of Contract

- 3.2 Bidder shall include FOB price under Foreign cost and all local costs which are incurred in Sri Lanka including Agency Commission under Local Cost. Freight, cost of pre shipment inspection by Employer and Inspection and Testing by Independent Testing Agency shall be included in the summary of Bills. Total of Summary of each bill shall be carried forward to “Summary of Bills”.
- 3.3 Insurance shall be done by the Purchaser.
- 3.4 Shipping shall be done as specified in the **Clause 37** of Instruction to Bidders.
- 3.5 Quoted price of spare parts shall be valid for a period of 2 years from the date of award of the Contract.
4. **Schedule of Particulars**
- a) The bidders are necessarily be required to complete fully the schedule of particulars given in the Bidding document.
- b) Where catalogues, technical literature and drawings accompanying the bid, their references should be quoted in the Schedule of Particulars;
- c) Where the bidder's specification is not conforming to the minimum specification, the offer will not be accepted;
5. A rate and/or price is to be entered against each item in the Bills of Quantities whether quantities are stated or not. The cost of any item against which a rate has not been entered shall be deemed to be covered by other contract rates.
6. The Bills of Quantities contains Volumetric Displacement Type Water Meters & Spare Parts only.
7. Cost of combined allowance for pre-shipment inspection for two Engineers by the Employer shall be for the entire duration as per the **Clause 8.2** of the Conditions of Contract. If any shortage is found, the supplier shall bear the additional cost.
8. Cost of Inspection and Testing by the Independent Inspection and Testing Agency shall be as per the **Clause 8** of the Conditions of Contract.
9. The rates and/or prices entered against items in the Bills of quantities shall be excluding the VAT as the VAT is considered separately.
10. If any bidder has not quoted for both bills (Bill No.01 and Bill No. 02), their bid may be rejected by Technical Evaluation Committee.

BILL OF QUANTITIES

**SUPPLY AND DELIVERY OF NOS. OF
VOLUMETRIC DISPLACEMENT TYPE
..... mm. DOMESTIC WATER METERS AND SPARE PARTS**

CONTRACT NO :

BILL NO. 1 – Supply & Delivery of Water Meters

Item No.	Description	Qty	Unit	Rate		Amount	
				Foreign Component (FOB) USD or Any other recognized foreign currency accepted by CBSL	Local Component LKR	Foreign Component (FOB) USD or Any other recognized foreign currency accepted by CBSL	Local Component LKR
1.	Supply & delivery ofmm (DN) Volumetric Displacement type water meters with 2 nos. End-Connectors, 2 Nos. Coupling nuts and seals conforming to specifications		Nos.				
	Total carried forward to summary, Page No 9-...						

SUMMARY OF BILL NO. 01

Page Number	Unit	Amount	
		Foreign Cost (USD) or Any other recognized foreign currency accepted by CBSL	Local Cost (LKR)
Total of Page No. 9-...	-		
Freight	Sum		
Cost of Pre Shipment Inspection as per Clause no. 8.2 of General Conditions of Contract. No. of Pre-shipment inspection (to be filled by the bidder)	Sum		
Cost of Inspection and testing by Independent Testing & Inspection Agency	Sum		
Summary of Bill No 01 Carried to the Page No. 9-.....	-		

Name of the Independent Inspection Agency :

.....

BILL OF QUANTITIES

**SUPPLY AND DELIVERY OF NOS. OF
VOLUMETRIC DISPLACEMENT TYPE
..... mm. DOMESTIC WATER METERS AND SPARE PARTS**

CONTRACT NO :

BILL NO. 2 – Supply & Delivery of Spare parts

Item No.	Description	Qty	Unit	Rate		Amount	
				Foreign Component (FOB) USD or Any other recognized foreign currency accepted by CBSL	Local Component LKR	Foreign Component (FOB) USD or Any other recognized foreign currency accepted by CBSL	Local Component LKR
1.	Supply & delivery Spare parts ofmm (DN) above water meters as mentioned in clause 4 of the specification (Itemized price list shall be submitted with the bid) (Keep the provision for maximum of 20% of the quantities under Bill No.01)		Sets				
	Total carried forward to summary, Page No 9-...						

SUMMARY OF BILL NO. 02

Page Number	Unit	Amount	
		Foreign Cost (USD) or Any other recognized foreign currency accepted by CBSL	Local Cost (LKR)
Total of Page No. 9-...	-		
Freight	Sum		
Cost of Inspection and testing by Independent Testing & Inspection Agency	Sum		
Summary of Bill No 02 Carried to the Page No. 9-.....	-		

Name of the Independent Inspection Agency :

.....

NATIONAL WATER SUPPLY AND DRAINAGE BOARD

**SUPPLY AND DELIVERY OF NOS. OF
VOLUMETRIC DISPLACEMENT TYPE**

..... mm. DOMESTIC WATER METERS AND SPARE PARTS

CONTRACT NO. :

SUMMARY OF BILL

Bill No.		Amount	
		Foreign cost (USD) or Any other recognized foreign currency accepted by CBSL	Local Cost (LKR)
01	Supply and Delivery of Nos. of Volumetric Displacement type mm. Water Meters		
02	Supply and Delivery of Nos. of Spare parts of volumetric Displacement type mm. Water Meters		
	Sub Total		
	Less Discount (if any)	
	Total of Bid carried to Form of Bid (excluding VAT) in page no. 3-1.		

VAT Registration Number:.....

(A copy of the VAT registration certificate shall be annexed.)

Note: - The NWSDB VAT Registration No: - 4090 31820 7000

10. SPECIMEN FORMS

- **BID SECURITY**
- **CONTRACT AGREEMENT**
- **PERFORMANCE GUARANTEE**
- **LETTER OF ACCEPTANCE**

FORM OF BID SECURITY (Unconditional)

..... [issuing agency’s name, and address of issuing branch or office]

.....
.....

Beneficiary : Chairman
National Water Supply and Drainage Board
Galle Road, Ratmalana

Date..... BID SECURITY No :

We have been informed that [name of the Bidder ; if joint venture, list complete legal names of partners] (hereinafter called “the Bidder”) has submitted to you its bid dated [insert date] (hereinafter called “ the Bid”) for the execution / supply of
.[name of contract] under Contract No..... .

Furthermore, we understand that, according to your conditions, Bids must be supported by a Bid Security.

At the request of the Bidder, we [name of issuing agency] hereby irrevocably under take to pay you any sum or sums not exceeding in total an amount of [amount in figures]
.....[amount in words] upon receipt by us of your first demand in writing accompanied by a written statement stating that the Bidder is in breach of its obligation (s) under the bid conditions, because of the Bidder:

- (a). has withdrawn its Bid during the period of bid validity specified ; or
- (b). does not accept the correction of errors in accordance with the Instructions to Bidders (hereinafter “the ITB”) or
- (c). having been notified of the acceptance of its Bid by the Employer/ Purchaser during the period of Bid validity , (i) fails or refuses to execute the Contract Form, if required, or (ii) fails or refuses to furnish the Performance Security, in accordance with the ITB.

This Security shall expire: (a) if the Bidder is the successful bidder, upon our receipt of copies of the Contract signed by the Bidder and of the Performance Security issued to you by the Bidder, or (b) if the Bidder is not the successful bidder, upon the earlier of (i) our receipt of a copy of your notification to the Bidder that the Bidder was unsuccessful, otherwise it will remain in force up to [insert date].

Consequently, any demand of payment under this Security must be received by us the office on or before that date.....

.....[Signature (s) of authorized representative (s)]

**THE GOVERNMENT OF THE DEMOCRATIC SOCIALIST REPUBLIC OF
SRI LANKA**

MINISTRY OF

NATIONAL WATER SUPPLY AND DRAINAGE BOARD

**SUPPLY AND DELIVERY OF NOS. OF
VOLUMETRIC DISPLACEMENT TYPE**

..... mm. DOMESTIC WATER METERS AND SPARE PARTS

CONTRACT No.:

CONTRACT AGREEMENT

Contract Agreement made and entered into between the National Water Supply and Drainage Board, a corporate body duly established under the provisions of the National Water Supply and Drainage Board Law No. 2 of 1974 and having its Head Office at Ratmalana in Sri Lanka (hereinafter sometimes referred to as "the Board") of the one part and Messrs :
.....
.....which duly incorporated under the laws of Democratic Socialist Republic of Sri Lanka and having registered Its office at.....
.....(hereinafter called "the Supplier" which term of expression shall where the context so requires or admits mean and include its successors and permitted assigns) of the other part.

WHEREAS the Board is desirous of entering into a contract with the Supplier for the supply of
..... to at locations as specified in the Delivery Schedule and has accepted a Bid by the Supplier for the execution and completion of such works.

AND WHEREAS the Bills of Quantities or Schedule of Rates and Specifications and General Conditions of Contract describing the Works to be done have been prepared by the Board and the same have been signed by the parties hereto.

NOW it is hereby agreed as follows:

1. For the consideration hereinafter mentioned the Supplier shall, upon and subject to the conditions hereto annexed, complete the Works referred to in the said Bills of Quantities or Schedule of Rates and in the said Specifications and Conditions of Contract to the entire satisfaction of the Board on or before the
.....
.....subject to extras, omissions and variations to be determined by the Engineer as hereinafter provided.
2. The said General Conditions of Contract, the said Specifications, the said Bills of Quantities or Schedule of Rates, (a detailed list whereof is annexed hereto,) Instructions to Bidders, Contract Data, Schedule of Particulars and Form of Bid, all duly signed by the Board and the Supplier shall for all purposes whatsoever be read, regarded and construed as part and parcel of the Agreement.
3. The Supplier shall be paid for the said execution of the Works the sum of (Rs.....) hereinafter sometimes referred to as the "Contract Price" or such as shall become payable hereunder according to the terms of the Contract.
4. As security for the due and proper performance and fulfillment of this contract and for the due payment of all claims to which the Purchaser may be entitled hereunder, the Supplier hereby undertakes to maintain to the Purchaser with a Guarantee in favor of the Purchaser from a Bank approved by the Engineer, as surety (Rs)
..... which said Performance Guarantee shall remain in force and shall not be discharged until the Engineer shall have granted a Final Certificate to the effect that the Supplier has duly discharged and completed all his obligations under this contract and that there is no sum whatever due to the Purchaser at the date of such Final Acceptance Certificate under this Contract.
5. The following terms used in this Agreement and or in the Specifications shall be understood as having the meanings hereby ascribed to them, namely;
 - (a) "The Procurement Committee" shall mean the Procurement Committee appointed for the purpose of determining the Tender.
 - (b) "The Contractor" or "The Supplier" shall mean the person or persons, firm or firms, company or companies who have contracted for the supply and delivery of the materials, equipment and installation herein specified and includes its successors and permitted assigns.
 - (c) "The Chairman" shall mean the officer for the time being holding the office of or acting as the Chairman, National Water Supply and Drainage Board.

- (d) "The Engineer" shall mean the Officer for the time being holding the Office of or acting to the General Manager, National Water Supply and Drainage Board.
- (e) "The Engineer's Representative" shall mean the authorized Representative of the Engineer immediately responsible for the supervision of the Works or any other person appointed from time to time by the Engineer to act as Engineer and notified in writing to the Contractor.
- (f) "The Government" shall mean the Government of the Democratic Socialist Republic of Sri Lanka.
- (g) "The Purchaser" or "The Board" shall mean the National Water Supply and Drainage Board.
- (h) "Months" shall mean calendar months.
- (i) "The Contract Documents" shall mean the Instructions to Bidders, Contract Data, Bidding Data, Schedule of Particulars, the General Conditions of Contract, the Form of Bid, the Specifications, Bill of Quantities, Addenda, Articles of Agreement and their annexure.
- (j) "The Contract Price" shall mean the sum stated in the Letter of Acceptance payable to the Contractor for the supply of Goods and Services in accordance with the provisions of the Contract.
- (k) "The Works" shall mean the supply, delivery and Installation of Goods and the Services.
- (l) "Variation" shall mean any alteration of the description of any item in the Bill of Quantities or of the Specifications which in the opinion of the Engineer, is required for the perfect completion of the Works outlined in the Agreement.
- (m) "RS or SL Rs." shall mean Sri Lanka Rupees.

IN WITNESS WHEREOF the parties hereto have set their hands and seal to these presents at the places and dates hereinafter mentioned.

Signed by the said Chairman, National Water Supply and Drainage Board and..... Board Member of the National Water Supply and Drainage Board at on the..... day of Two Thousand andin the presence of the following Witnesses.

Chairman Board Member

NATIONAL WATER SUPPLY AND DRAINAGE BOARD

WITNESSES

Signature 1: Signature 2 :
Name : Name :
Address Address :
.....

Signed by the said in the capacity of at on theday of Two Thousand and in the presence of the following Witnesses.

.....
Signature of Supplier

WITNESSES

Signature 1: Signature 2 :
Name : Name :
Address Address
.....
Capacity Capacity

FORM OF PERFORMANCE SECURITY (Unconditional)

.....[*Issuing Agency’s Name and Address of issuing Branch or Office*]
.....
.....

Beneficiary : Chairman
National Water Supply and Drainage Board
Galle Road, Ratmalana

Date

PERFORMANCE SECURITY No.:

We have been informed that [name of Contractor/Supplier] (hereinafter called “the Contractor”) has entered into Contract No. dated with you, for the Supply & installation of//..... [name of contract and brief description of Works] (hereinafter called “the Contract”).

Furthermore, we understand that according to the conditions of the Contract, a performance security is required.

At the request of the Supplier, we [name of Agency] hereby irrevocably under take to pay you any sum or sums not exceeding in total and amount of [in figures][in words], such sum being payable in the types and proportions of currencies in which the Contract Price is payable , upon receipt by us of your first demand in writing accompanied by a written statement stating that the Contractor is in breach of its obligation (s) under the Contract, without your needing to prove or to show grounds for your demand or the sums specified therein.

This shall expire, no later than the day of , 20 [28 Days beyond the scheduled contract completion date] and any demand for payments under it must be received by us at this office on or before that date.

.....
[Signature (s)]

Signature and seal of the guarantor

T&C/
.....
.....
.....

.....-20.....

Regd. Post

Ms.
.....
.....

Dear Sirs,

**SUPPLY AND DELIVERY OF NOS. OF VOLUMETRIC DISPLACEMENT
TYPE mm. DOMESTIC WATER METERS AND SPARE PARTS**

CONTRACT NO:

Letter of Acceptance

We are pleased to inform you that your offer submitted on[date] on the above tender, amounting to United States Dollars
..... (US\$/=) Plus Sri Lanka Rupees
.....
(LKR) Plus Custom Duties has been accepted subject to the following conditions.

- Applicable VAT will be payable on production of Tax Invoices. The Registered No. for NWSDB for VAT is 4090318207000.
- Volumetric Displacement
Type Domestic Water Meters and Spare Parts

Inspection and Testing of goods should be carried as per **Clause 8** of General Conditions of Contract with respect to quantity, quality and loading prior to shipment and certificates should be forwarded to Deputy General manager (.....)

All Water Meters and Spare Parts under this contract shall be delivered at such places, in such quantities as specified in the Delivery Schedule and Contract Period is months from the date hereof.

The liquidated damages for any delay beyond the above period shall be LKR/= per shipment per Day not exceeding 10% of the total contract price.

Performa Invoice shall be submitted within 14 days from the date hereof, requesting the NWS&DB to open the Letter of Credit in the supplier's name.

Performance Security in the form of demand guarantee in the prescribed format (a copy annexed) from a recognized bank operating in Sri Lanka approved by the Central Bank of Sri Lanka for an amount of 10% of the total Contract Price valid for a period of 28 Days beyond the Contract Period from the date hereof shall be submitted within 14 Days from the date hereof.

Please acknowledge receipt of this letter by a return fax and make arrangements to sign the Agreement by prior appointment with the Asst. General Manager (Tenders & Contracts) within 28 Days.

Engineer's Representative of this contract is

Please contact Deputy General Manager (.....) on Tele No. for further action on this contract.

Yours faithfully,
National Water Supply & Drainage Board

General Manager

- Cc: 1. Secretary, Ministry of
2. Auditor General – Duplicate offer and a copy of the Tender Board decision attached.
3. Addl. General Manager (.....)
4. Deputy General Manager (.....)
5. Deputy General Manager (Finance)
6. Deputy General Manager (IA)
7. Asst. General Manager (.....)
8. Chief Engineer (.....)

Stores Copy

11. APPENDICES

APPENDIX 1- DETAILS OF SIMILAR MANUFACTURES COMPLETED WITHIN THE LAST FIVE YEARS AND ONGOING

Name and Address of Employer	Name and details of Contract	Value of Contract	Period of Contract Date		Remarks (Completed/ ongoing etc.)	Value of work remaining incomplete
			From	To		

APPENDIX 2 - FINANCIAL STATEMENT

Summary of assets and liabilities based on the audited financial statements for the any three financial years (Current statement may be unaudited) within last five (05) years together with the Financial Performance as indicated in the following schedule shall be submitted.

If the business has not been in operation for three years following schedule shall be submitted for the period that the business has been in operation together with the aforesaid financial statements.

Bidders whose financial capability is marginally less to undertake this bid may show credit facilities available to them from a Banks. (supported by a letter from Bank, issued one month prior to closing of Bids).

11 Financial performance for the any three financial years within last five (05) years

Year	xxxx	xxxx	xxxx
Turnover from Contracting			
Fixed Assets (FA)			
Current Assets (CA)			
Current Liabilities (CL)			
Long Term Liabilities (LL)			
Net Worth = Total Assets – Total Liabilities			
Current Ratio = $\frac{\text{Current Assets}}{\text{Current Liability}}$			
Liquidity Ratio = $\frac{\text{Current Assets (except stock)}}{\text{Current Liability}}$			
Gearing Ratio = $\frac{\text{Debt Capital} \times 100}{\text{Total Capital Employed}}$			
$\frac{\text{Turnover}}{\text{Total Operating Assets}} \times 100$			
$\frac{\text{Net Profit}}{\text{Total Assets}} \times 100$			

APPENDIX 2A – AUTHORIZATION FOR BANK REFERENCES

BIDDER SHALL FILL THIS FORM AND PROVIDE WITH THE BID

..... *[Bidder's Name]*
.....*[Address]*
.....
.....

Manager *[Name of Bank]*
.....*[Address]*
.....
.....

Dear Sir,

We hereby Authorize the National Water Supply & Drainage Board, on behalf of the Procurement Committee, to seek references of Bank details in order to evaluate the financial statues of our company M/s
.....*[Contract Name]* in connections
with the *[Contract Number]* bid,
submitted by us.

Yours faithfully,

.....
.....
Authorized officer of the Bidder.

Note : If there are more than one bank, separate letters should be submitted for each Bank.

APPENDIX 3 - LETTER FOR CONFORMATION OF CAPABILITY OF PRODUCTION AND SUPPLY ACCORDING TO DELIVERY SCHEDULE

[Address of the Manufacturer]

.....
.....
.....

Chairman, Procurement Committee

.....
.....

SUPPLY AND DELIVERY OF NOS. OF VOLUMETRIC DISPLACEMENT TYPE mm. DOMESTIC WATER METERS AND SPARE PARTS

CONTRACT NO.....

We,[Name of Manufacturer]

of.....

.....
[address of manufacturer]confirm that we have sufficient production capacity to produce the quantity ofmm volumetric displacement domestic type water meters submitted in our bid and shall deliver them according to the delivery schedule indicated in the bid.

.....
Authorised Officer of the Manufacturer

.....
Seal of the Company.

Name:

Certified by

.....
Authorized officer of the Bidder

.....
Seal of the Company

Name :.....

APPENDIX 4 - MANUFACTURER'S AUTHORIZATION TO SIGN THE CONTRACT

[This letter of authorization should be on the letter head of the Bidder and should be signed by a person with the proper authority to sign documents that are binding on the Bidder. The bidder shall include it in its bid].

Date : [insert date (as day, month and year) of Bid Submission]
No. : [insert contract number]

To : Chairman, Procurement Committee
.....
.....

SUPPLY AND DELIVERY OF NOS. OF VOLUMETRIC DISPLACEMENT TYPE mm. DOMESTIC WATER METERS AND SPARE PARTS.

CONTRACT NO.....

We[insert complete name of Bidder], who are Bidders ofmm volumetric displacement domestic type Water meters and spare parts, having factories at[insert full address of Bidder's factories], do hereby authorize [insert complete name and address of Bidder] to submit a bid, the purpose of which is to supply numbers ofmm volumetric displacement domestic type Water meters and spare parts supplied by us, [insert name of the Bidder] and to subsequently negotiate and sign the Contract.

We hereby extend our full guarantee and warranty in accordance with **Clause 15** of the General Conditions of Contract, with respect to the Goods offered by the above firm.

Duly authorized to sign this Authorization on behalf of :[insert complete name of the Bidder]

Signed :[insert signature(s) of authorized representative(s) of the Manufacturer]

Name :[insert complete name(s) of authorized representative(s) of the Bidder]

Title : [insert title]

Dated on day of[insert date of signing].

APPENDIX 5 - BIDDER’S AUTHORIZATION TO SIGN THE CONTRACT

[The Bidder shall require to fill in this Form in accordance with the instructions indicated. This letter of authorization should be on the letter head of the Bidder and should be signed by a person with the proper authority to sign documents that are binding on the Bidder. The bidder shall include it in its bid].

Date : [insert date (as day, month and year) of Bid Submission]
No. : [insert contract number]

To : Chairman, Procurement Committee,
.....,
.....,

**SUPPLY AND DELIVERY OF NOS. OF VOLUMETRIC DISPLACEMENT
TYPE mm. DOMESTIC WATER METERS AND SPARE PARTS.**

CONTRACT NO.....

We[insert complete name of the Bidder], who
.....[insert full address of Bidder], do hereby
authorize [insert complete name of Bidders authorize
officer who signs the contract] to submit a bid on behalf of our company and to subsequently
negotiate and sign the Contract. We will supply the goods as per the Contract.

Specimen Signature

Signed :[insert signature(s) of authorized representative(s) of
the Bidder]

Name :[insert complete name(s) of
authorized representative(s) of the Bidder]

Title : [insert title]

Duly authorized to sign this Authorization on behalf of :[insert
complete name of Bidder]

This is to certify that the seal and signatures of legal representative and authorized person affixed
to power of attorney attached hereto are found to be authentic.

.....
Signature of Attorney at Law

.....
Seal of Attorney at Law

In the place of(Address)

Date :.....

APPENDIX 6 - TOR FOR THE INDEPENDENT INSPECTION AGENCY

	Test	Measurement Value / Observation Comments
1	Q ₁ (min. flow)	
2	Q ₂ (transitional flow)	
3	Q ₃ (Permanent flow)	
4	Pressure test (acc. to the pressure rating in cl.5.3.4)	
5	Non return valve test	
6	Pressure loss test (acc. to the figures in cl. 5.3.5)	
7	Overall dimensions & thread dimensions	
8	Magnetic test (if applicable)	

**APPENDIX 7 - MANUFACTURER'S AWARENESS OF THE TOR FOR
INDEPENDENT INSPECTION AGENCY**

[Address of the Manufacturer]

.....
.....
.....

Chairman, Procurement Committee

.....,
.....,

**SUPPLY AND DELIVERY OF NOS. OF VOLUMETRIC DISPLACEMENT
TYPE mm. DOMESTIC WATER METERS AND SPARE PARTS.**

CONTRACT NO.....

We, [Name of Manufacturer] of

.....
..... [Address of
Manufacturer] confirm that we have noticed that

- a) Appendix 6 – TOR for Independent Inspection Agency
- b) **Clause 8.1** of General Conditions of contract

.....
Authorised Officer of the Manufacturer.

.....
Seal of the Company.

Name :.....

Certified by

.....
Authorized officer of the Bidder

.....
Seal of the Company

Name :.....

APPENDIX 8 - MANUFACTURER’S WARRANTY FOR THE GOODS (SUPPLIED UNDER THE CONTRACT)

[Address of the Manufacturer]

.....

Chairman,
 National Water Supply and Drainage Board,
 Galle Road, Ratmalana, Sri Lanka,

SUPPLY AND DELIVERY OF NOS. OF VOLUMETRIC DISPLACEMENT TYPE mm. DOMESTIC WATER METERS AND SPARE PARTS.

CONTRACT NO.....

We,[Name of Manufacturer] of [Address of Manufacturer] warrant that the goods supplied under this contract are new, unused, of the most recent or current models and have incorporated all recent improvements, and no defects arising out of the design, material or workmanship from any act that may be develop under normal use of the supplied goods.

If there is any defects during the warranty period specified in the **Clause 15** of the General Conditions of Contract, we shall attend to repair or replace the defective goods with all reasonable speed without any cost to the Purchaser.

Also we enclose further details in the given table below.

Part/ Section	Warranty period

.....
 Authorised Officer of the Manufacturer.

.....
 Seal of the Company.

Name :.....

Certified by

.....
 Authorized officer of the Bidder

.....
 Seal of the Company

Name :.....

APPENDIX 9 - MANUFACTURER'S GUARANTEE FOR THE REPLACEMENT OF UNACCEPTABLE GOODS SUPPLIED UNDER THE CONTRACT

[Address of the Manufacturer]

.....
.....

Chairman,
National Water Supply and Drainage Board,
Galle Road, Ratmalana, Sri Lanka,

SUPPLY AND DELIVERY OF NOS. OF VOLUMETRIC DISPLACEMENT TYPE mm. DOMESTIC WATER METERS AND SPARE PARTS.

CONTRACT NO.....

We,[Name of Manufacturer] of

.....

.....[Address of Manufacturer] guarantee that

we shall unconditionally undertake to replace any unacceptable goods supplied under this contract with no additional cost to the employer ensuring timely completion of the project.

If any case we fail to replace the unacceptable goods, we agree that the NWSDB shall not make balance 25% payment and encash the Performance Guarantee. We further aware that NWSDB will immediately suspend issuing bidding documents to us and thereafter action shall be taken to blacklist us.

.....

Authorised Officer of the Manufacturer

.....

Seal of the Company

Name :.....

Certified by

.....

Authorized officer of the Bidder

.....

Seal of the Company

Name :.....

APPENDIX 10 – FORMAT FOR BIDDER’S TEST CERTIFICATES

APPENDIX (A) - METER SIZE AND OVERALL DIMENSIONS

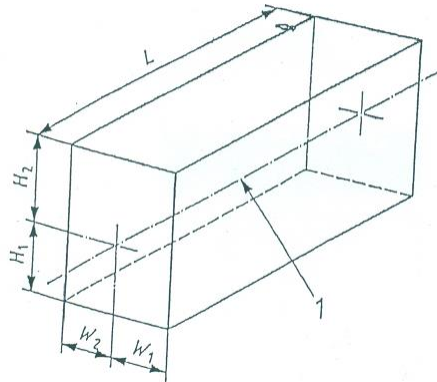

Key

1 - Pipe Axis

H_1, H_2, L, W_1 and W_2 define the height, length and width respectively of a cuboid within which the water meter contained (the cover being at right angle to its closed position). H_1, H_2, W_1, W_2 are maximum dimensions. L is a fixed value with specified tolerances.

Figure 1 – Meter Size and Overall Dimensions

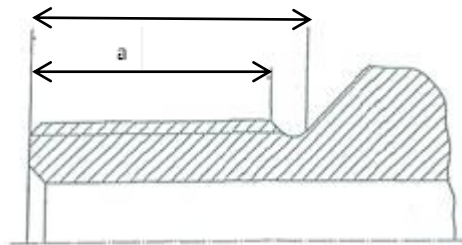

Figure 2 – Threaded connection

APPENDIX (B)
 ISO 40641:2005(E)

TABLE 1 – WATER METER DIMENSIONS

Dimensions in millimeters

Size DN ^a	a _{min}	b _{min}	L _b (Preferred)	L _b (Alternatives)	W ₁ ;W ₂	H ₁	H ₂
15	10	12	165	80,85,100,105,110,114,115,130,134,135,145,170,175,180,190,200,220	65	60	220
20	12	14	190	105,110,115,130,134,135,165,175,195,200,220,229	65	60	240
25	12	16	260	110,150,175,200,210,225,273	100	65	260
32	13	18	260	110,150,175,200,230,270,300,321	110	70	280
40	13	20	300	200,220,245,260,270,387	120	75	300
50			200	170,245,250,254,270,275,300,345,350	135	216	390
65			200	170,270,300,450	150	130	390
80			200	190,225,300,305,350,425,500	180	343	410
100			250	210,280,350,356,360,375,450,650	225	356	440
125			250	220,275,300,350,375,450	135	140	440
150			300	230,325,350,450,457,500,560	267	394	500
200			350	260,400,500,508,550,600,620	349	406	500
250			450	330,400,600,660,800	368	521	500
300			500	380,400,800	394	533	533
350			500	420,800	270	300	500
400			600	500,550,800	290	320	500
500			600	500,625,680,770,800,900,1000	365	380	520
600			800	500,750,820,920,1000,1200	390	450	600
800			1200	600	510	550	700
>800			1.25xDN	DN	0.65xDN	0.65xDN	0.75xDN

DN: Nominal size of flanges and threaded connections

Tolerance on length: DN: 15 to DN 40-0/-2 mm:
 DN: 50 to DN 300 – 0/-3 mm:
 DN: 350 to DN 400-0/-5 mm.

Tolerances on lengths of meters greater than DN 400 shall be agreed upon between the user and manufacturer.

APPENDIX (C)
ISO 2859:1:199

TABLE 1 – SAMPLE SIZE CODE LETTERS (SEE 10.1 AND 10.2)

Lot Size	Special Inspection Levels				General Inspection Levels		
	S-1	S-2	S-3	S-4	I	II	III
2 to 8	A	A	A	A	A	A	B
9 to 15	A	A	A	A	A	B	C
16 to 25	A	A	B	B	B	C	D
26 to 50	A	B	B	C	C	D	E
51 to 90	B	B	C	C	C	E	F
91 to 150	B	B	C	D	D	F	G
151 to 280	B	C	D	E	E	G	H
281 to 500	B	C	D	E	F	H	J
501 to 1 200	C	C	E	F	G	J	K
1 201 to 3 200	C	D	E	G	H	K	L
3 201 to 10 000	C	D	F	G	J	L	M
10 001 to 35 000	C	D	F	H	K	M	N
35 001 to 150 000	D	E	G	J	L	N	P
150 001 to 500 000	D	E	G	J	M	P	Q
500 001 and over	D	E	H	K	N	Q	R

APPENDIX (D) - DETAILS REFERRED TO IN CONDITIONS OF CONTRACT

Minimum amount of third party insurance
for any one incident, number of incidents unlimited

SL Rs 1,000,000.00

APPENDIX (E)

TABLE 2-A - SINGLE SAMPLING PLANS FOR NORMAL INSPECTION (MASTER TABLE)

Sample size code letter	Sample size	Acceptance Quality limit. AQL, in percent nonconforming items and nonconformities per 100 items (normal inspection)																									
		0.010	0.015	0.025	0.040	0.065	0.10	0.15	0.25	0.40	0.65	1.0	1.5	2.5	4.0	6.5	10	15	25	40	65	100	150	250	400	650	1000
		Ac Re	Ac Re	Ac Re	Ac Re	Ac Re	Ac Re	Ac Re	Ac Re	Ac Re	Ac Re	Ac Re	Ac Re	Ac Re	Ac Re	Ac Re	Ac Re	Ac Re	Ac Re	Ac Re	Ac Re	Ac Re	Ac Re	Ac Re	Ac Re	Ac Re	Ac Re
A	2			↓	↓	↓	↓	↓	↓	↓	↓	↓	↓	↓	0 1	↓	↓	1 2	2 3	3 4	5 6	7 8	10 11	14 15	21 22	30 31	
B	3			↓	↓	↓	↓	↓	↓	↓	↓	↓	↓	↓	0 1	↑	↓	1 2	2 3	3 4	5 6	7 8	10 11	14 15	21 22	30 31	44 45
C	5			↓	↓	↓	↓	↓	↓	↓	↓	↓	↓	↓	0 1	↑	↓	1 2	2 3	3 4	5 6	7 8	10 11	14 15	21 22	30 31	44 45
D	8			↓	↓	↓	↓	↓	↓	↓	↓	↓	↓	↓	0 1	↑	↓	1 2	2 3	3 4	5 6	7 8	10 11	14 15	21 22	30 31	44 45
E	13			↓	↓	↓	↓	↓	↓	↓	↓	↓	↓	↓	0 1	↑	↓	1 2	2 3	3 4	5 6	7 8	10 11	14 15	21 22	30 31	44 45
F	20			↓	↓	↓	↓	↓	↓	↓	↓	↓	↓	↓	0 1	↑	↓	1 2	2 3	3 4	5 6	7 8	10 11	14 15	21 22	↑	↑
G	32			↓	↓	↓	↓	↓	↓	↓	↓	↓	↓	↓	0 1	↑	↓	1 2	2 3	3 4	5 6	7 8	10 11	14 15	21 22	↑	↑
H	50			↓	↓	↓	↓	↓	↓	↓	↓	↓	↓	↓	0 1	↑	↓	1 2	2 3	3 4	5 6	7 8	10 11	14 15	21 22	↑	↑
J	80			↓	↓	↓	↓	↓	↓	↓	↓	↓	↓	↓	0 1	↑	↓	1 2	2 3	3 4	5 6	7 8	10 11	14 15	21 22	↑	↑
K	125			↓	↓	↓	↓	↓	↓	↓	↓	↓	↓	↓	0 1	↑	↓	1 2	2 3	3 4	5 6	7 8	10 11	14 15	21 22	↑	↑
L	200			↓	↓	↓	↓	↓	↓	↓	↓	↓	↓	↓	0 1	↑	↓	1 2	2 3	3 4	5 6	7 8	10 11	14 15	21 22	↑	↑
M	315			↓	↓	↓	↓	↓	↓	↓	↓	↓	↓	↓	0 1	↑	↓	1 2	2 3	3 4	5 6	7 8	10	14 15	21 22	↑	↑
N	500			0 1	↑	↓	1 2	2 3	3 4	5 6	7 8	10 11	14	21 22	↑	↑	↑	↑	↑	↑	↑	↑	↑	↑	↑	↑	↑
P	800		0 1	↑	↓	1 2	2 3	3 4	5 6	7 8	10 11	14 15	21	↑	↑	↑	↑	↑	↑	↑	↑	↑	↑	↑	↑	↑	↑
Q	1250	0 1	↑	↓	1 2	2 3	3 4	5 6	7 8	10 11	14 15	21 22	↑	↑	↑	↑	↑	↑	↑	↑	↑	↑	↑	↑	↑	↑	↑
R	2000	↑	↑	1 2	2 3	3 4	5 6	7 8	10 11	14 15	21 22	↑	↑	↑	↑	↑	↑	↑	↑	↑	↑	↑	↑	↑	↑	↑	↑

↓ = Use the first sampling plan below the arrow. If sample size equals or exceeds lot size carry out 100% inspection

↑ = Use the first sampling plan above the arrow

Ac = Acceptance number

Re = Rejection number

APPENDIX (F) - FACTORY INSPECTION/AUDIT REPORT

Factory Inspection/ Audit report

The Whole Manufacturing Process, Whole Manufacturing System and the Whole facility shall be audited by the Certification Agency and issue the relevant certifications.

Certification agency shall certify whether the above adhere to the intended proper practices and report any steps of the procedures skipped by the manufacturers. The inspection/ Audit process shall carry out comprehensive surveillance of the above.

Scope of the Inspection/ Audit

1. General Information
2. Foreign Trade Capacity
3. Product Research and Development Capacity
4. Quality Management System and Product Certification
5. Product Capacity & Quality Control
6. Photos

Part A : General Information

Section 1 : Company Overview

1.1 Legal Validity					
Does the Company have a Valid business license?	Yes	No	Others	Valid Date	
Year of establishment				Registration Number	
Registered Address					
Actual Address					
Is the annual review done By local authority (Industrial & Commercial Bureau ?)					
Registered Capital					
Name of the legal representative					
Business Scope					

1.2 Basic Information			
Contact Person		E – Mail	
Phone Number		Fax Number	
URL/Web Address			
Company type	Manufacture	Foreign Trader	Combined
Type of ownership	Limited Company	Public company	Joint Venture
Type of owner ship	Stated-owned owned	Private Owner	Wholly foreign- enterprises
Subsidiary factory/ies			
Product Manufactured/sold scope			

1.3 Company Building Information	
According to:	
Land certificate	Real estate certificate
Lease agreement	
The land occupy about :	sq. meters
The workshop occupy about :	sq. meters

Section 2 Human Resources

2.1 company (Organization) Chart

2.2 Explanation of Code and Employee Details		
Code	Department	Numbers of Employees
A		
B		
C		
D		
E		
F		
G		
H		
Number in total		

2.3 key staff			
Title	Full Name	Education	Working experience for trade/total experience

Remark :Above information of key staff was based on interview with company representatives.

Part B : Foreign Trade Capacity

Section 1 : Export Overall Situation

1.1 Export Overall Situation	
Does the company have a valid export license ?	Yes No
The Export license registration Number ?	
The number of foreign trading staff with relevant trading experience ?	Within 1 year 2-05 years 5 – 10 years Over 10 years Total Staff ...
The language freely used by foreign trade staff	
Annual revenue of previous year	
Estimated export revenue for this year	
Oversea agent	
Nearest port	
Acceptable quotation	FOB CIF
Acceptable payment type	LC T/T
What is the company's projected average lead time from PO confirmation to production EX works delivery ?	

Section 2 : Export Business Capacity

2.1 Market Distribution		
Market	Main Project	% of total Business Volume (last year)

Remark : Above information of business volume was claimed by company representative. Include data for all exports to Europe, North America and Japan

Section 3 : Supplier Management

3.1 Supplier Management		
Item	Content	Observation/Comments
1	Does the company established and implement an effective suppliers' assessment procedure ?	Have the written procedures and followed records Have the written procedures but no records Have the relevant records without written procedure Have no written procedures or followed records
2	Does the company have An updated list of approved suppliers ?	The approved Suppliers list was updated in Have the written suppliers without approved signature or date Provide the some suppliers names No approved suppliers list

Section 4 :After Sale Service Capacity

4.1 After Service capacity		
Item	Content	Observation/ comments
1	Is there a procedure to conduct random Product inspection after final packaging in Place ?	<p>Have clear standards and written inspection Records</p> <p>No written standards but had inspection Reports</p> <p>Have the procedures but no inspection records</p> <p>It's not necessary to carry out the inspection</p>
2	Is there a clear procedure for handling Customer complaints?	<p>Has the clear procedure and followed Records</p> <p>Has the procedure but no written records</p> <p>No written procedures or records</p>
3	Can the finished / packaged product be Traced by lot identification to the Appropriate raw materials test reports?	<p>Have the procedure to trace the raw Materials</p> <p>Can trace main materials</p> <p>Can trace production data</p> <p>Can't trace products</p>
4	Are corrective & preventive actions Mechanism established and implemented Effectively (including the suppliers /sub-Contractors control, incoming inspection, process control, final inspections and Customer complaint) ?	<p>Has the clear procedure and followed Records</p> <p>Has the procedure but no written records</p> <p>No written procedures or records</p>

Part C : Product report & Development Capacity

1.1 Product Research and Development capacity	
The amount of R&D and relevant working Experience	Within 1 year staff 2 – 5 years staff ... 5 – 10 years Staff Over 10 years staff Total engineers
What is the main job responsibility for R&D engineers ?	
Does the company have its own brand for the company, or ODM , OEM, others ?	
Is there any relevant design input, output, Review, verification and validation Documentation available to the auditor for review?	
Does the R&D staff normally have any special Software to design new products ? If yes , please list the main software.	
Does the company have an effective design Change control procedure in place ?	
Please list the patent certifications and Qualifications license.	

Part D : Quality Management System and Product Certification

1.1 Quality Management System and Product Certification	
Has the company obtained a valid certification for their quality management system ? such as ISO9001 , QC80000 and etc.	
Is product certification done in terms of selling Designation (UL for US,CCC for china, CE for Europe.....) at the company ? 1) product certification list ? if has 2) sample of product certification , if has (at least one key products) ? 3) Copy of product certification sample (01 – 05 key products , if has) ?	

Part E : Production Capacity & control

Section 1 : Production Capacity

1.1 Production Situation (Top three Product Categories)			
Product Category	Capacity on top month	Average Capacity	Total in 2011

Section 2 : Production process Control

2.1 Production Process Control		
Item	Content	Observations/ Comments
1	Are the Environmental Conditions, Such as Tidiness and cleanliness being controlled and Suitable for the operation performed ?	Very tidy Normal Need to improve Very poor
2	Are the following items / documents provided At appropriate location and under control When necessary ?	Work instructions/procedures Workmanship standard/acceptance Golden sample /Approval sample Product picture Verbal by workshop director
3	Are written instructions available for incoming materials inspections/testing ? Is the relevant record maintained ?	Has instructions and uniformly followed Has instructions but no written records Check the products by packing staff
4	Are written inspections/ testing instructions Available for finished products ? Is the relevant record maintained ?	Have instructions and uniformly followed Have instructions but no written records Check the products by packing staff

Item	Content	Observations/ Comments
5	What type of inspections is used for finished Products ?	Random inspections 100% inspection visual inspection function inspection
6	Are non- conforming units clearly marked/segregated to prevent accidental dispatch?	Marked and segregated Segregated but not marked clearly Not found in site
7	How are the non – conforming units handled ?	Repaired and re-inspection Picked out Used under control Others

Section 3 : Company Development/ Expansion Plans

3.1 Company Development/Expansion Plans		
Item	Company Development Action(s)	Timeframe

Part H : Photos of documents

Section 1 : photo of documents

Description : Business License

Description : Lease Agreement

Description : Patent Certificate

Section 2 : Photos of Company

2.1 Photos of Company and product sample

Description : Company Gate

Description : Workshop

Description : Office

Description : Warehouse

Description : Showroom

APPENDIX (G) – IN PROCESS INSPECTION CERTIFICATE (DURING PRODUCTION INSPECTION)

In Process Inspection Certificate (During Production Inspection)

Inspection agency shall carry out the inspections when 20% of the order quantity has been produced so as to ensure that the contractual obligations regarding product specifications and other requirements have fulfilled and complied with.

Scope and Procedure

Sample size selection from the lot

Sample size code letter shall be selected from table 1 – sample size code Letters in appendix D depending on the Lot size and General Inspection Level 1.

Then the table 2 – A – Single Sampling Plans for normal inspections (Master Table) in Appendix E shall be employed for sample size determination and allowable failure percentage.

Following are the inspection levels to be used:

Accepting Quality Limit – 2.5

Single Sample

Normal inspection

From the above, Sample size shall be obtained from table 2- A in Appendix E. Subsequently a sample of the above size is selected from lot using standard Random Tables.

Each meter in the sample shall be subjected to the following parameters & features.

1. Q1
2. Q2
3. Q3
4. Pressure Test (no Leak-pass, any leak-fail)
5. Magnetic Test (Response to the magnet- fail, No response –pass)
6. Non –return valve test (function-pass, not function –fail)
7. Pressure loss test

8. Overall dimensions 7 thread dimensions
9. Any meter failing in any of the above eight tests shall be considered to have failed totally.

Visual Inspections

All components parts being used in the manufacture of the meters to be supplied under this Contract shall be carefully inspected for their quality.

i.e. precision of machining, casting, surface finish etc.

alignments, tolerances between matching parts, positioning of parts in the subassemblies and overall assembly etc.

APEENDIX (H) – PRE PRODUCTION CERTIFICATE

Pre Product Certificate

Inspection Agency shall inspect all individual components to be used in the manufacturing and assembly process of the meters to be supplied under this contract.

Inspections to be carried out,

1. Visual
2. Measurements (acc. to manufacturer's specifications, QA plan data)
3. Fits & tolerances (acc. to Manufacturer's specifications, QA plan data)
4. Mating of parts (proper fit, alignment etc)
5. Machined surfaces

Parts to be subjected to these tests,

1. Brass housing
2. Polymer/plastic wheels of the mechanism
3. Other polymer/ plastic parts of the mechanism
4. Non return valve
5. Counter assembly (parts, liquid sealing)
6. Working chamber /parts
7. Lid, pin etc. assembly
8. End connector brass unions/ huts, seals etc
9. Meter sealing for tamper proofing
10. Other parts of the meter assembly

APPENDIX (I) – QULAITY CONTROL/ASSURANCE SYSTEM CERTIFICATE

Quality Control / Assurance system Certificate

Verification and certifications whether the manufacturer has a documentary Quality(control) plan for the materials, manufactured and sub – contracted parts in the production process.

Quality plan formats shall generally include,

Part number & Description

Measurements Method

Quantity to be checked

Frequency

Specification limits

Deviation/Defects

Actions on Deviations/Defects

Responsible division/person

Description of the Sampling Procedure, Standards used for Sampling.

APPENDIX 11 - CONFIRMATION OF SUPPLYING GOODS MANUFACTURED AT THE FACTORY QUOTED

[This form shall be filled on the letter head of the manufacturer's company]

Date :.....

Chairman, Procurement Committee,
.....
.....

SUPPLY & DELIVERY OF VOLUMETRIC DISPLACEMENT TYPE DOMESTIC WATER METERS AND SPARE PARTS.

CONTRACT NO.:

We
(Name & Address of the Water-Meter manufacturer) hereby guarantee that,

1. The Supply of Volumetric Displacement Type Water Meters for the above contract shall be manufactured at the manufacturing factory at.....
.....
..... (Address of the manufacturing factory).
2. The Supply of Spare Parts for the above contract shall be manufactured at the manufacturing factory at
..... (Address of the manufacturing factory).

.....
Signature of the
Chief Executive Officer/
General Manager of the manufacturer

.....
Seal of the Company

Name :
Address :
.....

The above signed declare that the statement made above is true and correct in every detail.

.....
Signature of the Attorney at Law

.....
Seal of the Attorney

Name :
Address :

APPENDIX 12 – AFFIDAVIT BY THE BIDDER

I of being a (Buddhist or any other religionist), do hereby solemnly sincerely and truly declare and affirm as follows.

- 01. I am the Affirmant above named.

- 02. I hereby declare that I have applied for the contract of National Water Supply and Drainage Board bearing No: and my spouse or dependent does not work in National Water Supply and Drainage Board on permanent, casual or contract basis.

The foregoing affidavit having been read over and explained to the affirmant above named who having understood its nature content and context affirmed hereto and set his usual signature hereto in on this day of 20

Before me

.....
Declarant

.....
Justice of the peace /
Commissioner for Oaths

APPENDIX 13 - LETTER FOR CONFORMATION OF ISSUING CERTIFICATE ACCREDITED LAB/ INDEPENDENT INSPECTION AGENCY ON PROPER FUNCTIONING OF THE WATER METERS.

{ADDRESS}

.....
.....
.....

Chairman, Procurement Committee

.....,
.....,

SUPPLY AND DELIVERY OF NOS. OF VOLUMETRIC DISPLACEMENT TYPEMM DOMESTIC WATER METERS AND SPARE PARTS.

CONTRACT NO :

We(*name of the Bidder*)
of (Address
of Bidder) Certify That We Unconditionally Undertake That Accredited Laboratory/
Independent Inspection Agency
..... (*Name and Address of the Accredited
Laboratory/ Independent Inspection Agency*) issue a Certificate Ensuring That Water Meters
Inspection Shall Fit Properly And Adequately To Ensure Proper Functioning.

.....
Authorized Signature of Bidder

.....
Company Seal

APPENDIX 14 - SAMPLE OF PRE- SHIPMENT TEST CERTIFICATE

1. Background Information

Order No. :					
Coordinator :					
Description of commodity (Name, Model, Quantity.....)					
Buyer (Name, Address.....)					
Seller (Name, Address.....)					
P/I No.	N/A				
LC No.	N/A				
Others.	N/A				
Nature of inspection	Item	Satisfactory		Non conforming	
	Item	Satisfactory	Non conforming	Rejected	Subject to buyer's evaluation

2. Instrument

During the inspection, the following instrument calibration status has been checked for inspection.

No.	Name	ID No.	Measuring range	Calibrated (Yes/ No/ NA)	Certificate No. (Optional)
1					
2					

3. Quantity check

3.1 Reference documents

3.2 Method of quantity check

Item	Description	REQ. quantity	ACT. quantity	Remark

4. Marking check

4.1 Reference documents

4.2 Sample size

4.3 Mark on water meter

4.4 Remarks

5. Visual Quality Check

5.1 Sample size

5.2 Remarks

6. Dimension check

6.1 Sample size

6.2 Reference documents

Item	Serial No.	Overall Length	G3/4” thread on body	G3/4” thread on nuts	R1/2” thread on nipple

6.3 Remarks

7. Witness testing

7.1 Sample size

7.2 Reference document

7.3 Hydraulic pressure test

Item	Serial No	Phase 1	Phase 2	Results

7.4 Measurement – error test

Serial No.	Flow rate point	Flow rate (L/h)	Permissible error	Result	Water meter reading (L)

7.5 Non return test

Item	Serial No	Pressure	Time	Results

7.6 Pressure loss test

Item	Serial No	Pressure loss		Results
		Required	Checked	

For Q₃ (1600 L/h)

Item	Serial No	Pressure loss		Results
		Required	Checked	

**Measurement error results
Data sheet 1**

Serial No.	Q ₄			Q ₃		Q ₂		Q ₁	
	100L			100L		10L		1L	
	Start	Finish	Error (%)	Finish	Error (%)	Finish	Error (%)	Finish	Error (%)

Data sheet 2 (after continuous endurance test)

Serial No.	Q ₄			Q ₃		Q ₂		Q ₁	
	100L			100L		10L		1L	
	Start	Finish	Error (%)	Finish	Error (%)	Finish	Error (%)	Finish	Error (%)

Data sheet 3 (after discontinuous endurance test)

Serial No.	Q ₄			Q ₃		Q ₂		Q ₁	
	100L			100L		10L		1L	
	Start	Finish	Error (%)	Finish	Error (%)	Finish	Error (%)	Finish	Error (%)

7.8 Remarks

APPENDIX 15 - SAMPLE OF ENDURANCE TEST CERTIFICATE

1. Background Information

Order No. :					
Coordinator :					
Description of commodity (Name, Model, Quantity.....)					
Buyer (Name, Address.....)					
Seller (Name, Address.....)					
P/I No.	N/A				
LC No.	N/A				
Others.	N/A				
Nature of inspection	Item	Satisfactory		Non conforming	
	Item	Satisfactory	Non conforming	Rejected	Subject to buyer's evaluation

2. Instrument

During the inspection, the following instrument calibration status has been checked for inspection.

No.	Name	ID No.	Measuring range	Calibrated (Yes/ No/ NA)	Certificate No. (Optional)
1					
2					

3. Quantity check

3.1 Reference documents

3.2 Method of quantity check

Item	Description	REQ. quantity	ACT. quantity	Remark

4. Marking check

4.1 Reference documents

4.2 Sample size

4.3 Mark on water meter

4.4 Remarks

5. Visual Quality Check

5.1 Sample size

5.2 Remarks

6. Dimension check

6.1 Sample size

6.2 Reference documents

Item	Serial No.	Overall Length	G3/4" thread on body	G3/4" thread on nuts	R1/2" thread on nipple

6.3 Remarks

7. Witness testing

7.1 Sample size

7.2 Reference document

7.3 Hydraulic pressure test

Item	Serial No	Phase 1	Phase 2	Results

7.4 Measurement – error test

Serial No.	Flow rate point	Flow rate (L/h)	Permissible error	Result	Water meter reading (L)

7.5 Non return test

Item	Serial No	Pressure	Time	Results

7.6 Pressure loss test

Item	Serial No	Pressure loss		Results
		Required	Checked	

For Q₃ (1600 L/h)

Item	Serial No	Pressure loss		Results
		Required	Checked	

7.7 Endurance Test

7.7.1 Measurement – Error test after continuous endurance test

Serial No.	Flow rate point	Flow rate (L/h)	Permissible error	Error	Max. Variation	Variation	Water Meter reading (L)

7.7.2 Measurement – Error test after discontinuous endurance test

Serial No.	Flow rate point	Flow rate (L/h)	Permissible error	Error	Max. Variation	Variation	Water Meter reading (L)

**Measurement error results
Data sheet 1**

Serial No.	Q ₄			Q ₃		Q ₂		Q ₁	
	100L			100L		10L		1L	
	Start	Finish	Error (%)	Finish	Error (%)	Finish	Error (%)	Finish	Error (%)

Data sheet 2 (after continuous endurance test)

Serial No.	Q ₄			Q ₃		Q ₂		Q ₁	
	100L			100L		10L		1L	
	Start	Finish	Error (%)	Finish	Error (%)	Finish	Error (%)	Finish	Error (%)

Data sheet 3 (after discontinuous endurance test)

Serial No.	Q ₄			Q ₃		Q ₂		Q ₁	
	100L			100L		10L		1L	
	Start	Finish	Error (%)	Finish	Error (%)	Finish	Error (%)	Finish	Error (%)

7.8 Remarks

APPENDIX 16 - ENTITLED ALLOWANCES ON FOREIGN TRAVELS & RELATED EXPENSES

Category of Countries

Category No.	Countries					Combined & Incidental Allowance
1 st category	Afganistan Albania Algeria Azerbaijan Bahamas Balarus Barbados Belize Bhutan Bolivia Bosnia Botswana	Burundi Cambodia Canary Island Capevrde Cooks Island Domenica El Salvador Etihiyopiya Equatorial Gabon Gambia Gibraltar	Guam Kiribati Lao Peoples Dem.Rep. Lesothe Liechtenstein Nacedonia Rep. Malawi Malta Mauritania Mongolia Montenegro Myanmar	Nambia Nauru Netherlands Anti Nicaragua Palau Paraguay Samoa Sao Tome & Prince Serbia Sierra Leon Soloman Island Somalia	Tanzania Swaziland Tajikistan Tunisia Uganda Uzbekistan	US\$ 200 + US\$ 75
2 nd category	Antigue Barbuda Armenia Argentina Bulgaria Bangaldesh Brunei Cameroon Coted Ivoria Costa Rica	Ecuador Fiji French Guiana Guyana Grenada Gerogia Guatemala Greenland	Guinea Bissaw Hawai Haiti Honduras Ireland Iraq Jamaica Korea Dem.Rep.	Liberia Mexico Micronesia Fed. Monaco Mozambique Papua new Guinea Suriname Yeman Rep.	Yogoslavia Tahiti Tonga Vanuatu	US\$ 260 + US\$ 75
3 rd category	Baharain Chile Cyprus Egypt Arab Rep. Estonia Guinea Hungary Indonesia Iran Islamic Rep. Kenya	Kuwait Lithuania Madagascar Mauritius Malayasia Maldives Morocco Macedonia Rep Nepal Oman	Pakistan Panama Peru Pholippines Poland Quarter Romania Ruwada Saudi Arabia Solvenia	Sriyan Arab Rep. South Africa St.Lucia Sudan Thailand Togo Trinidad & Tobago Uruguay Ukrain Venezuela	Vietnam Zaire Zambia Zimbabwe	US\$ 330 + US\$ 75
4 th category	Belgium Benin Burkina Faso Comoros Central African Rep. Colombia Congo	Croatia Cuba Czech Republic Dem.Rep.of Congo Djibouti Greece Iceland	India Ivory Coast Jordan Kazakhstan Latvia Lebanon Luxemburg	Mali New Caledonia Nigeria Portugal Slovak Rep. Spain Taiwan	Turkey United Arab Emirates	US\$ 400 + US\$ 75
5 th category	Angola Australia Austria Brazil Canada Chad	China (Beijin) Denmark France Germany Finland Hongkong	Israel Italy Japan Libiya Netherland New Zealand	Niger Norway Russia Senagal Swedan Seychelles	Singapore South Korea Switzerland United Kingdom USA	US\$ 530 + US\$ 75