

REVISED ON 09-09-2024

**THE GOVERNMENT OF THE DEMOCRATIC SOCIALIST
REPUBLIC OF SRI LANKA**

MINISTRY OF

NATIONAL WATER SUPPLY AND DRAINAGE BOARD

**SUPPLY AND DELIVERYmmNOS. OF
BRASS STOP VALVES**

CONTRACT No.:

REVISED ON 09-09-2024

**NATIONAL WATER SUPPLY AND DRAINAGE BOARD
GALLE ROAD
RATMALANA
SRI LANKA**

.....
(MONTH & YEAR)

DOCUMENT ISSUANCE CERTIFICATE

(To be filled at the time of issue by the authorized issuing officer)

- 1. STANDARD BIDDING DOCUMENT NUMBER : NWSDB/SBD/SUP/Stop Valves/LC/V1
- 2. CONTRACT NUMBER :
- 3.a) ISSUED TO :
-
- b) ADDRESS:
-
- c) TELEPHONE NUMBER:.....
- d) FACSIMILE NUMBER :
- 4. a) TENDER FEE : Rs. RECEIVED IN CASH/ BANK DRAFT
- b) RECEIPT /BANK DRAFT NUMBER:
- 5. NUMBER OF COPIES ISSUED:
- 6. NUMBER OF CANCELLED COPIES ISSUED :
- 7. CANCELLED COPY FEE : Rs. RECEIVED/ NOT RECEIVED
(IN CASH/ BANK DRAFT)
- 8. SUPPLIER’S BUSINESS REGISTRATION NUMBER :
- 9. a) ISSUING OFFICER :
- b) DESIGNATION :
- c) SIGNATURE :
- 10. PLACE OF ISSUE :
- 11. SEAL :
- 12. DATE : TIME :

Table of Contents

SECTION		<u>PAGE NUMBER</u>	
	Document Issuance Certificate	(i)	
	Table of contents	(ii)	(iii)
	Checklist of Submissions	(iv)	
	Invitation for Bids	(v)	
1	Instructions to Bidders	1-1	1- 20
2	Conditions of contract	2-1	2 - 21
3.	Form of Bid	3 - 1	3 - 2
4.	Bidding Data	4 - 1	4 - 3
5.	Contract Data		
	* General	5 - 1	
	* Delivery Schedule	5 - 2	
	* Payment Schedule	5 - 3	
6.	Specifications	6 - 1	6 – 8
7.	Key features of Specifications	7 - 1	7– 2
8.	Deviation from Specifications	8 – 1	
9.	Schedule of Particulars	9 - 1	9– 3
10.	Bills of Quantities		
	* Preamble Notes on Pricing	10 - 1	10 - 2
	* Bills of Quantities	10 - 3	
	* Summary of Bills	10 -4	
	* Grand Summary	10 -5	

11	Specimen Forms	
	* Bid Security	11 - 1
	* Contract Agreement	11 - 2 11 - 4
	* Performance Security	11 - 5
	* Advance Payment Security	11 - 6
	* Letter of Acceptance	11 - 7 11- 8
12	Appendices	
	• Appendix 1 - Details of similar manufactures completed within the last five years and ongoing similar ones	12 - 1
	• Appendix 2 - Financial statement	12 - 2
	• Appendix 2A - Authorization for Bank references	12 -3
	• Appendix 3 – Letter for Manufacture’s Authorization to sign the Contract	12 - 4
	• Appendix 4 – Letter for Confirmation of Capability of production and Supply according to Delivery Schedule	12 - 5
	• Appendix 5 - Bidder’s Authorization to sign the Contract.	12 - 6
	• Appendix 6 - TOR for Independent Inspection Agency	12 –7
	• Appendix 7 - Manufacturer’s awareness of the TOR for the Independent Inspection Agency	12 - 8
	• Appendix 8 - Manufacturer’s Warranty for the goods supplied under the contract	12 - 9
	• Appendix 9 - Specimen Form of Test Certificate for Pipes and Fittings	12 - 10
	• Appendix 10 - Manufacturer’s Guarantee For the Replacement of unacceptable Goods Supplied under the Contract	12 – 11
	• Appendix 11 - Affidavit by the Bidder	12 - 12

CHECKLIST OF SUBMISSIONS

CHECKLIST OF SUBMISSIONS

* **Note: Please mark 'Y' in the cages under the 'Remarks' column if submissions are made. 'N' or 'N/A' should be marked for cases of 'No submissions' and 'Not applicable' respectively.**

	Description	Reference		Remarks *
		Instructions to Bidders		
(a)	Documentary evidence to establish eligibility of bidder.	Page No 1 - 3, 1 - 4	Clause No. 2.1 and 3.2	
(b)	Certified copy of business registration.	Page No. 1 - 3	Clause No. 2.1	
(c)	Documentary evidence to establish qualifications for the performance of the Contract.	Page No. 1 - 3	Clause No. 2.2	
(d)	Documentary evidence to establish that goods offered are from an eligible source and origin.	Page No. 1 - 4	Clause No. 2.2 (b), (1)	
(e)	The Bidder's technical and production capability necessary to perform the Contract.	Page No. 1 - 4	Clause No . 2.2(b) (iii)	
(f)	Test Samples.	Page No. 1- 5, 1-7	Clause 10.1 Clause 3.4	
(g)	Duly completed all sections of Bidding Documents. (Bidder shall fill the Schedule of Particulars, BOQ etc., indicating any deviations to specifications under the corresponding schedule of particulars)	Page No. 1 - 5, 1 - 7	Clause No. 6.1, 10.1	
(h)	Subsequent Addendum/Addenda. (if any)	Page No. 1 - 6	Clause No. 8	
(i)	Bid Security.	Page No. 1 - 9	Clause No. 13	
(j)	Product Conformity Certificates and Quality Assurance Certificates for items offered.	Page No. 1 - 7, 1-5	Clause No. 10.1, 3.3	
(k)	In the case of a bidder offering to supply Goods under the Contract which the bidder does not manufacture or otherwise produce, authorisation by the manufacturer or producer of Goods as his accredited agent.	Page No. 1 - 4	Clause No. 2.2 (b)	
(l)	The agreement of the manufacturer or producer to confirm that the supply will be made in accordance with the Delivery Schedule.	Page No. 1 - 4	Clause No. 2.2(b) (iii)	
(m)	Proof of Authorization.	Page No. 1 - 7	Clause No. 10.1 (g)	
(n)	Declaration regarding local accredited agent and local agent's commission.			
(o)	Certified Copy of the VAT Registration Certificate.	Page No. 1 - 8	Clause No. 11.3	
(p)	Certificates of registration of the contract with the registrar of public contracts as per the Act No. 3 of 1987. (If required)	Page No. 1-20	Clause No. 36	
	Any other document as given below:			

INVITATION FOR BIDS

MINISTRY OF

NATIONAL WATER SUPPLY AND DRAINAGE BOARD

INVITATION FOR BIDS

**TENDER FOR SUPPLY AND DELIVERYmm NOS OF
BRASS STOP VALVES**

CONTRACT No.:

1. The Chairman, Department Procurement Committee, National Water Supply and Drainage Board (NWSDB), Galle Road, Ratmalana, Sri Lanka, on behalf of the National Water Supply & Drainage Board now invites sealed bids for the supply and Delivery ofmm Nos of Brass Stop Valves up to closing of bids at hours on
2. Bidding documents available at the office of the Assistant General Manager (Tenders and Contracts), National Water Supply & Drainage Board (NWSDB), Galle Road, Ratmalana, Sri Lanka between 09:00 hours to 15:00 hours on normal working days up to, upon payment of a non refundable fee of Rs.plus applicable VAT.
3. Bids will be opened immediately after the closing of Bids, at the office of the Assistant General Manager (Tenders and Contracts), NWSDB, Galle Road, Ratmalana, Sri Lanka. Bidders or their authorized representatives may be present at the opening of bids.
4. Bidding Documents will be issued only to those who are manufacturers or their local accredited agents for supply of Brass Stop Valves upon production of a letter of request for documents on a business letterhead.
5. The bidder shall submit a valid certificate of registration of the Contract as per the Act No. 3 of 1987 with Register of Public Contract and subsequent paper advertisement published on 16th October 2018 in Daily News.
6. To be eligible for contract award, the successful bidder shall not have been blacklisted.
7. Alternative bids shall not be accepted.
8. Sealed bids may be either dispatched by registered post or hand delivered to the office of Assistant General Manager (Tenders and Contracts), NWSDB, Galle Road, Ratmalana, Sri Lanka to receive on or before the closing time. Late bids will be rejected.
9. All Bids shall be accompanied by a bid security of Rupees.....and the bid security should be valid upto.....(*Specify the Date*).
10. Bidding Documents may be inspected free of charge at the office of the Assistant General Manager (Tenders and Contracts), NWSDB, Galle Road, Ratmalana, Sri Lanka.
11. For further details, please contact the Assistant General Manager (Tenders and Contracts), NWSDB, Galle Road, Ratmalana, Sri Lanka on telephone number 94 -11-2605328 or 94-11-2638999 Ext. 1750 or facsimile number 94 -11-2635885.

**Chairman,
NATIONAL WATER SUPPLY AND DRAINAGE BOARD**

MINISTRY OF

NATIONAL WATER SUPPLY AND DRAINAGE BOARD

INVITATION FOR BIDS

**TENDER FOR SUPPLY AND DELIVERYmm NOS OF
BRASS STOP VALVES**

CONTRACT No.:

1. The Chairman, Project Procurement Committee, National Water Supply and Drainage Board (NWSDB), *(Insert Relevant Project Office Address)* on behalf of the National Water Supply & Drainage Board now invites sealed bids for the supply and Delivery ofmm Nos of Brass Stop Valves up to closing of bids at hours on
2. Bidding documents are available at the office of the Project Director, National Water Supply & Drainage Board (NWSDB), *(Insert Relevant Project Office Address)* between 09:00 hours to 15:00 hours on normal working days up to, upon payment of a non refundable fee of Rs. plus applicable VAT.
3. Bids will be opened immediately after the closing of Bids, at the office of Project Director, National Water Supply & Drainage Board (NWSDB), *(Insert Relevant Project Office Address)* Bidders or their authorized representatives may be present at the opening of bids.
4. Bidding Documents will be issued only to those who are manufacturers or their local accredited agents for supply of Brass Stop Valves upon production of a letter of request for documents on a business letterhead.
5. The bidder shall submit a valid certificate of registration of the Contract as per the Act No. 3 of 1987 with Register of Public Contract and subsequent paper advertisement published on 16th October 2018 in Daily News.
6. To be eligible for contract award, the successful bidder shall not have been blacklisted.
7. Alternative bids shall not be accepted.
8. Sealed bids may be either dispatched by registered post or hand delivered to the office of Project Director, Project Procurement Committee, National Water Supply & Drainage Board (NWSDB), *(Insert Relevant Project Office Address)* to receive on or before the closing time. Late bids will be rejected.
9. All Bids shall be accompanied by a bid security of Rupees and the bid security should be valid upto *(Specify the Date)*.
10. Bidding Documents may be inspected free of charge at the office of The Chairman, Project Procurement Committee, National Water Supply & Drainage Board, NWSDB, *(Insert Relevant Project Office Address)*
11. For further details, please contact The Chairman, Project Procurement Committee, National Water Supply & Drainage Board, *(Insert Relevant Project Office Address)* on telephone number or Ext. or facsimile number

Project Director,

.....WSP

MINISTRY OF

NATIONAL WATER SUPPLY AND DRAINAGE BOARD

INVITATION FOR BIDS

TENDER FOR SUPPLY AND DELIVERYmm NOS OF
BRASS STOP VALVES

CONTRACT No.:

1. The Chairman, Regional Procurement Committee, National Water Supply and Drainage Board (NWSDB),
(Insert Relevant RSC Address) on behalf of the National Water Supply & Drainage Board now invites sealed bids for the supply and Delivery ofmm Nos of Brass Stop Valves up to closing of bids at hours on
2. Bidding documents are available at the office of the Deputy General Manager, National Water Supply & Drainage Board (NWSDB),
..... (Insert Relevant RSC Address) between 09:00 hours to 15:00 hours on normal working days up to, upon payment of a non refundable fee of Rs. plus applicable VAT.
3. Bids will be opened immediately after the closing of Bids, at the office of The Chairman, Regional Procurement Committee, National Water Supply & Drainage Board (NWSDB),
.....(Insert Relevant RSC Address) Bidders or their authorized representatives may be present at the opening of bids.
4. Bidding Documents will be issued only to those who are manufacturers or their local accredited agents for supply of Brass Stop Valves upon production of a letter of request for documents on a business letterhead.
5. The bidder shall submit a valid certificate of registration of the Contract as per the Act No. 3 of 1987 with Register of Public Contract and subsequent paper advertisement published on 16th October 2018 in Daily News.
6. To be eligible for contract award, the successful bidder shall not have been blacklisted.
7. Alternative bids shall not be accepted.
8. Sealed bids may be either dispatched by registered post or hand delivered to the office of Deputy General Manager, National Water Supply & Drainage Board (NWSDB)
..... (Insert Relevant RSC Address) to receive on or before the closing time. Late bids will be rejected.
9. All Bids shall be accompanied by a bid security of Rupees.....and the bid security should be valid upto.....(Specify the Date).
10. Bidding Documents may be inspected free of charge at the office of the Deputy General Manager, National Water Supply & Drainage Board, NWSDB,
..... (Insert Relevant RSC Address)
11. For further details, please contact the Deputy General Manager, National Water Supply & Drainage Board,
.....(Insert Relevant RSC Address) on telephone number orExt. or facsimile number

DGM,
(RSC.....)

3. FORM OF BID

THE GOVERNMENT OF THE DEMOCRATIC SOCIALIST REPUBLIC OF SRI LANKA

MINISTRY OF

NATIONAL WATER SUPPLY AND DRAINAGE BOARD

**SUPPLY AND DELIVERYmmNOS
BRASS STOP VALVES**

CONTRACT No.:

FORM OF BID

The Chairman,
National Water Supply and Drainage Board,
Galle Road,
Ratmalana.
Sri Lanka

I/We, the undersigned, having authority to sign this Bid and having read and fully acquainted myself/ourselves with the contents of the Information and Instructions to Bidders and Terms and Conditions of Bid pertaining to the above Bid, along with Bills of Quantities thereto, do hereby undertake to supply the Goods and Services referred to therein, in accordance with the aforesaid Instructions, Terms and Conditions, Specifications, Bidding Data & Contract Data, for a total Price of Rupees.....

.....(in word)
LKR..... (in Figure) (excluding VAT). The make up of the aforesaid total Bid Price is given in the accompanying Bills of Quantities.

I/We confirm that this offer shall be open for acceptance until as given in the Bidding Data and that it will not be withdrawn or revoked prior to that date.

I/We attach hereto the following documents as part of my/our Bid.

1. Duly completed sections 1 to 12 of Bidding Documents.
2. Documentary evidence to establish eligibility and qualification of bid.
3. Documentary evidence to establish that goods are offered from an eligible source and origin.
4. Documentary evidence for Manufacturer's Authorization to sign the contract on behalf of the manufacturer.
5. Confirmation of capability of Production and supply according to delivery schedule.
6. Documentary evidence to establish eligibility of goods offered.
7. Bid Security.
8. Documentary evidence to establish qualifications for the performance of the Contract.
9. Bidding Data.
10. Any other document.

I/We declare that the photostat copies of documents and certificates submitted as part of my/our Bid are true copies of such documents and certificates. Also in case of ISO 9001 : 2015 certificate(s), and product conformity certificates as given in the specifications, I/we confirm that I/we have verified that the certificate issuing authority has accreditation to issue same and materials offered conform to the ISO 9001 : 2015 certificates and the specified product standard certificates.

I/We further agree to the right of the Board to debar me/us from participating in its future bids in the event that my/our submitted copies or documents are found to be forged or tampered with.

I/We understand that you are not bound to accept the lowest bid and that you reserve the right to reject any or all bids or to accept any part of a bid without assigning any reasons thereto.

I/We undertake to adhere to the Delivery Schedule given in **Contract Data**.

My/Our Bank Reference is as follows:

Signature of Bidder :

Name of Bidder :

Capacity :

Address :

Telephone Number :

E-mail Number :

Facsimile Number :

Date :

Seal :

Witnesses

1. Name :-

Capacity :

Address :

Signature :-

2. Name :-

Capacity :-

Address :

Signature :-

THE GOVERNMENT OF THE DEMOCRATIC SOCIALIST REPUBLIC OF SRI LANKA

MINISTRY OF

NATIONAL WATER SUPPLY AND DRAINAGE BOARD

**SUPPLY AND DELIVERYmmNOS
BRASS STOP VALVES**

CONTRACT No.:

FORM OF BID

PD (.....),
.....,
.....,
.....,
.....[Insert relevant Project Office address]

I/We, the undersigned, having authority to sign this Bid and having read and fully acquainted myself/ourselves with the contents of the Information and Instructions to Bidders and Terms and Conditions of Bid pertaining to the above Bid, along with Bills of Quantities thereto, do hereby undertake to supply the Goods and Services referred to therein, in accordance with the aforesaid Instructions, Terms and Conditions, Specifications, Bidding Data & Contract Data, for a total Price of Rupees.....

.....(in word)
LKR..... (in Figure) (excluding VAT). The make up of the aforesaid total Bid Price is given in the accompanying Bills of Quantities.

I/We confirm that this offer shall be open for acceptance until as given in the Bidding Data and that it will not be withdrawn or revoked prior to that date.

I/We attach hereto the following documents as part of my/our Bid.

1. Duly completed sections 1 to 12 of Bidding Documents.
2. Documentary evidence to establish eligibility and qualification of bid.
3. Documentary evidence to establish that goods are offered from an eligible source and origin.
4. Documentary evidence for Manufacturer's Authorization to sign the contract on behalf of the manufacturer.
5. Confirmation of capability of Production and supply according to delivery schedule.
6. Documentary evidence to establish eligibility of goods offered.
7. Bid Security.
8. Documentary evidence to establish qualifications for the performance of the Contract.
9. Bidding Data.
10. Any other document.

I/We declare that the photostat copies of documents and certificates submitted as part of my/our Bid are true copies of such documents and certificates. Also in case of ISO 9001 : 2015 certificate(s), and product conformity certificates as given in the specifications, I/we confirm that I/we have verified that the certificate issuing authority has accreditation to issue same and materials offered conform to the ISO 9001 : 2015 certificates and the specified product standard certificates.

I/We further agree to the right of the Board to debar me/us from participating in its future bids in the event that my/our submitted copies or documents are found to be forged or tampered with.

I/We understand that you are not bound to accept the lowest bid and that you reserve the right to reject any or all bids or to accept any part of a bid without assigning any reasons thereto.

I/We undertake to adhere to the Delivery Schedule given in **Contract Data**.

My/Our Bank Reference is as follows:

Signature of Bidder :

Name of Bidder :

Capacity :

Address :

Telephone Number :

E-mail Number :

Facsimile Number :

Date :

Seal :

Witnesses

1. Name :-

Capacity :

Address :

Signature :-

2. Name :-

Capacity :-

Address :

Signature :-

THE GOVERNMENT OF THE DEMOCRATIC SOCIALIST REPUBLIC OF SRI LANKA

MINISTRY OF

NATIONAL WATER SUPPLY AND DRAINAGE BOARD

**SUPPLY AND DELIVERYmmNOS
BRASS STOP VALVES**

CONTRACT No.:

FORM OF BID

DGM (.....)
.....
.....
.....[Insert relevant RSC address]

I/We, the undersigned, having authority to sign this Bid and having read and fully acquainted myself/ourselves with the contents of the Information and Instructions to Bidders and Terms and Conditions of Bid pertaining to the above Bid, along with Bills of Quantities thereto, do hereby undertake to supply the Goods and Services referred to therein, in accordance with the aforesaid Instructions, Terms and Conditions, Specifications, Bidding Data & Contract Data, for a total Price of Rupees..... (in word) LKR..... (in Figure) (excluding VAT). The make up of the aforesaid total Bid Price is given in the accompanying Bills of Quantities.

I/We confirm that this offer shall be open for acceptance until as given in the Bidding Data and that it will not be withdrawn or revoked prior to that date.

I/We attach hereto the following documents as part of my/our Bid.

1. Duly completed sections 1 to 12 of Bidding Documents.
2. Documentary evidence to establish eligibility and qualification of bid.
3. Documentary evidence to establish that goods are offered from an eligible source and origin.
4. Documentary evidence for Manufacturer's Authorization to sign the contract on behalf of the manufacturer.
5. Confirmation of capability of Production and supply according to delivery schedule.
6. Documentary evidence to establish eligibility of goods offered.
7. Bid Security.
8. Documentary evidence to establish qualifications for the performance of the Contract.
9. Bidding Data.
10. Any other document.

I/We declare that the photostat copies of documents and certificates submitted as part of my/our Bid are true copies of such documents and certificates. Also in case of ISO 9001 : 2015 certificate(s), and product conformity certificates as given in the specifications, I/we confirm that I/we have verified that the certificate issuing authority has accreditation to issue same and materials offered conform to the ISO 9001 : 2015 certificates and the specified product standard certificates.

I/We further agree to the right of the Board to debar me/us from participating in its future bids in the event that my/our submitted copies or documents are found to be forged or tampered with.

I/We understand that you are not bound to accept the lowest bid and that you reserve the right to reject any or all bids or to accept any part of a bid without assigning any reasons thereto.

I/We undertake to adhere to the Delivery Schedule given in **Contract Data**.

My/Our Bank Reference is as follows:

Signature of Bidder :

Name of Bidder :

Capacity :

Address :

Telephone Number :

E-mail Number :

Facsimile Number :

Date :

Seal :

Witnesses

1. Name :-

Capacity :

Address :

Signature :-

2. Name :-

Capacity :-

Address :

Signature :-

4. BIDDING DATA

The Bidding Data is a part of Instructions to Bidders and should be read in conjunction with the Instructions to Bidders.

If there is a discrepancy found in the Instructions to Bidders and the Bidding Data, the Content in the Bidding Data shall supersede the Content in the Instructions to Bidders.

(Note: What is typed in italic letters are guide lines to prepare the Bidding Data and they shall be removed after preparation of the Bidding Data.)

BIDDING DATA

(Please note that the Clause numbers given here under are that of Instructions to Bidders)

Clause Reference Number Instructions to Bidders

- (1.1) The Supplier is expected to supplymmNos Brass Stop Valves
- (2.2a) That the manufacturer shall have produced and supplied at least Nos of Brass Stop Valves during the last five years.
(Documentary evidence to justify shall be submitted)
- (2.2b) ii) Working Capital ^{*1} + present available credit facilities for the company^{*2} + credit facilities exclusively for this contract - 0.1 x current work commitments^{*3} > Rs.....^{*4}
- *1 Working Capital = Current Assets – Current Liabilities
- *2 A letter to prove the availability of credit facilities issued by a within a month prior to date of closing of Bids.
- *3 current work commitment = work remaining uncompleted
(Documentary evidence to justify shall be submitted)
- *4 80% of estimated cost of the Bid.
- (3.5) No of sample Brass Stop Valve required is and each shall be packed in a suitable plastic box, sealed properly submitted with the bid.
- (4) Funds required for this contract is available under
- (6.2) The address for the purchasing of Bidding Document
- Assistant General Manager (Tenders & Contracts)
National Water Supply and Drainage Board
Galle Road,
Ratmalana.
Telephone : 011-2605328
Fax : 011-2635885
- (13.2) The amount of Bid Security shall be Sri Lanka Rupees.
- (13.3) The validity of Bid Security shall be up to (specify the date)
- (14.1) The period of Bid validity shall be 91 days from the date of closing of Bid
- (17.2) (a) The inner and outer envelopes shall be addressed as follows:
- The Chairman, Department Procurement Committee
C/o, Assistant General Manager (Tenders and Contracts)
National Water Supply and Drainage Board
Galle Road,
Ratmalana.
- (c) “Not to be opened before (Time) on(Date)

- (18.1) The Procurement Committee’s address for the purpose of bid submission (and on behalf of the Board) is:

The Chairman, Department Procurement Committee,
C/o, Assistant General Manager (Tenders and Contracts),
National Water Supply and Drainage Board,
Galle Road,
Ratmalana,

The deadline for submission of bid

Date: Time :

- (21.1) The place for opening of Bids,

Tenders and Contracts Section,
National Water Supply and Drainage Board,
Galle Road,
Ratmalana,

- (24.1) Add to Clause

If a Bid does not meet any one of the requirements (a), (b), (c) & (d) of **Clause 24.1**, it will be considered substantially non responsive and rejected by the procurement committee.

- (26.1) Add to the Clause

Samples submitted with the bid shall be tested for the conformity to the specifications. If the test results do not conform to the specifications, the bid shall not be considered for further evaluation and rejected by the procurement committee.

- (26.4) Add to Clause

Bill of Manhole covers and surface boxes will be evaluated and awarded separately.

Preference for Domestic Manufacturers for GOSL funded suppliers.

When manufacturer’s of Domestic Manhole covers & Surface boxes are allowed to bid with Foreign Manufacturers, domestic preference for Domestic Manhole covers & Surface boxes manufacturers shall be applied for Manhole covers & Surface boxes supplies. Domestic Manufacturers are eligible for margin of Preference of 20% in comparison of their Bids with Foreign Manhole covers & Surface boxes, manufacturers subjected to the following conditions.

- a) Bidder shall establish to the satisfaction of the Procurement Committee that,
- (i) Labour, raw materials components from within Sri Lanka shall be indicated separately and will account to minimum of Thirty percent (30%) of EXW (Ex works) price of the Manhole covers & Surface boxes offered.
 - (ii) The production facility in which these Domestic Manhole covers & Surface boxes would be manufactured at least since the time of Bid submission.

b) In addition to the above, bidder shall satisfy the following:

- (i) For an individual / sole proprietorship the bidder shall be a Sri Lankan.
- (ii) For partnership fifty percent (50%) of member of the partnership shall be Sri Lankan.
- (ii) For an individual firm:
 - Such firm shall be registered in Sri Lanka; and
 - Shall have more than fifty percent (50%) ownership by Sri Lankans.

(32.2) The prevailing rate of stamp duty on contracts for supply of goods is NIL

(33.1) The amount of Performance Guarantee shall be 10% of the Contract Price.

(34.1) Advance payment shall be limited to 20% of the contract price.

BIDDING DATA

(Please note that the Clause numbers given here under are that of Instructions to Bidders)

Clause Reference Number
Instructions to Bidders

- (1.1) The Supplier is expected to supplymmNos Brass Stop Valves
- (2.2a) That the manufacturer shall have produced and supplied at least Nos of Brass Stop Valves during the last five years.
- (2.2b) ii) Working Capital *1 + present available credit facilities for the company*2 + credit facilities exclusively for this contract - 0.1 x current work commitments*3 > Rs.....*4
- *1 Working Capital = Current Assets – Current Liabilities
 - *2 A letter to prove the availability of credit facilities issued by a within a month prior to date of closing of Bids.
 - *3 current work commitment = work remaining uncompleted
(Documentary evidence to justify shall be submitted)
 - *4 80% of estimated cost of the Bid.
- (3.5) No of sample Brass Stop Valve required is and each shall be packed in a suitable plastic box, sealed properly submitted with the bid.
- (4) Funds required for this contract is available under
- (6.2) The address for the purchasing of Bidding Document
Project Director,
National Water Supply and Drainage Board,
.....,
.....,
.....(Insert Relevant Project office Address)
Telephone :
Fax :
- (13.2) The amount of Bid Security shall be Sri Lanka Rupees.
- (13.3) The validity of Bid Security shall be up to (specify the date)
- (14.1) The period of Bid validity shall be 91 days from the date of closing of Bid

(17.2) (a) The inner and outer envelopes shall be addressed as follows:
The Chairman, Project Procurement Committee.
.....
.....
.....
.....(Insert Relevant Project Office Address)

(c) “Not to be opened before (Time) on(Date)

(18.1) The Procurement Committee’s address for the purpose of bid submission (and on behalf of the Board) is:

The Chairman, Project Procurement Committee.
.....
.....
.....
.....(Insert Relevant Project Office Address)

The deadline for submission of bid

Date: Time :.....

(21.1) The place for opening of Bids,

.....
National Water Supply and Drainage Board.
.....
.....
.....(Insert Relevant Project Office Address)

(24.1) Add to Clause

If a Bid does not meet any one of the requirements (a), (b), (c) & (d)of **Clause 24.1**, it will be considered substantially non responsive and rejected by the procurement committee.

(26.1) Add to the clause

Samples submitted with the bid shall be tested for the conformity to the specifications. If the test results do not conform to the specifications, the bid shall not be considered for further evaluation and rejected by the procurement committee.

(26.4) Add to Clause

Bill of Manhole covers and surface boxes will be evaluated and awarded separately.

Preference for Domestic Manufacturers for GOSL funded suppliers.

When manufacturer’s of Domestic Manhole covers & Surface boxes are allowed to bid with Foreign Manufacturers, domestic preference for Domestic Manhole covers & Surface boxes manufacturers shall be applied for Manhole covers &

Surface boxes supplies. Domestic Manufacturers are eligible for margin of Preference of 20% in comparison of their Bids with Foreign Manhole covers & Surface boxes, manufacturers subjected to the following conditions.

- c) Bidder shall establish to the satisfaction of the Procurement Committee that,
- (iii) Labour, raw materials components from within Sri Lanka shall be indicated separately and will account to minimum of Thirty percent (30%) of EXW (Ex works) price of the Manhole covers & Surface boxes offered.
 - (ii) The production facility in which these Domestic Manhole covers & Surface boxes would be manufactured at least since the time of Bid submission.
- d) In addition to the above, bidder shall satisfy the following:
- (i) For an individual / sole proprietorship the bidder shall be a Sri Lankan.
 - (ii) For partnership fifty percent (50%) of member of the partnership shall be Sri Lankan.
 - (iv) For an individual firm:
 - Such firm shall be registered in Sri Lanka; and
 - Shall have more than fifty percent (50%) ownership by Sri Lankans.
- (32.2) The prevailing rate of stamp duty on contracts for supply of goods is NIL
- (33.1) The amount of Performance Guarantee shall be 10% of the Contract Price.
- (34.1) Advance payment shall be limited to 20% of the contract price.

BIDDING DATA

(Please note that the Clause numbers given here under are that of Instructions to Bidders)

Clause Reference Number Instructions to Bidders

- (1.1) The Supplier is expected to supplymmNos Brass Stop Valves
- (2.2a) That the manufacturer shall have produced and supplied at least Nos of Brass Stop Valves during the last five years.
(Documentary evidence to justify shall be submitted)
- (2.2b) ii) Working Capital ^{*1} + present available credit facilities for the company^{*2} + credit facilities exclusively for this contract - 0.1 x current work commitments^{*3} > Rs.....^{*4}
- *1 Working Capital = Current Assets – Current Liabilities
 - *2 A letter to prove the availability of credit facilities issued by a within a month prior to date of closing of Bids.
 - *3 current work commitment = work remaining uncompleted
(Documentary evidence to justify shall be submitted)
 - *4 80% of estimated cost of the Bid.
- (3.5) No of sample Brass Stop Valve required is and each shall be packed in a suitable plastic box, sealed properly submitted with the bid.
- (4) Funds required for this contract is available under
- (6.2) The address for the purchasing of Bidding Document
- Deputy General Manager,
National Water Supply and Drainage Board,
.....,
.....,
.....(Insert Relevant RSC Address)
Telephone :
Fax :
- (13.2) The amount of Bid Security shall be Sri Lanka Rupees.
- (13.3) The validity of Bid Security shall be up to (specify the date)
- (14.1) The period of Bid validity shall be 91 days from the date of closing of Bid

(17.2) (a) The inner and outer envelopes shall be addressed as follows:

The Chairman, Regional Procurement Committee.
.....
.....
.....
.....(Insert Relevant RSC Address)

(c) “Not to be opened before (Time) on(Date)

(18.1) The Procurement Committee’s address for the purpose of bid submission (and on behalf of the Board) and bid opening is:

The Chairman, Regional Procurement Committee.
.....
.....
.....
.....(Insert Relevant RSC Address)

The deadline for submission of bid

Date: Time :.....

(21.1) The place for opening of Bids,

.....
National Water Supply and Drainage Board.
.....
.....
.....(Insert Relevant RSC Address)

(24.1) Add to Clause

If a Bid does not meet any one of the requirements (a), (b), (c) & (d) of Cause 24.1, it will be considered substantially non responsive and rejected by the procurement committee.

(26.1) Add to the clause

Samples submitted with the bid shall be tested for the conformity to the specifications. If the test results do not conform to the specifications, the bid shall not be considered for further evaluation and rejected by the procurement committee.

(26.4) Add to Clause

Bill of Manhole covers and surface boxes will be evaluated and awarded separately.

Preference for Domestic Manufacturers for GOSL funded suppliers.

When manufacturer’s of Domestic Manhole covers & Surface boxes are allowed to bid with Foreign Manufacturers, domestic preference for Domestic Manhole covers & Surface boxes manufacturers shall be applied for Manhole covers & Surface boxes supplies. Domestic Manufacturers are eligible for margin of

Preference of 20% in comparison of their Bids with Foreign Manhole covers & Surface boxes, manufacturers subjected to the following conditions.

- e) Bidder shall establish to the satisfaction of the Procurement Committee that,
- (v) Labour, raw materials components from within Sri Lanka shall be indicated separately and will account to minimum of Thirty percent (30%) of EXW (Ex works) price of the Manhole covers & Surface boxes offered.
 - (ii) The production facility in which these Domestic Manhole covers & Surface boxes would be manufactured at least since the time of Bid submission.
- f) In addition to the above, bidder shall satisfy the following:
- (i) For an individual / sole proprietorship the bidder shall be a Sri Lankan.
 - (ii) For partnership fifty percent (50%) of member of the partnership shall be Sri Lankan.
 - (vi) For an individual firm:
 - Such firm shall be registered in Sri Lanka; and
 - Shall have more than fifty percent (50%) ownership by Sri Lankans

(32.2) The prevailing rate of stamp duty on contracts for supply of goods is NIL

(33.1) The amount of Performance Guarantee shall be 10% of the Contract Price.

(34.1) Advance payment shall be limited to 20% of the contract price.

5. CONTRACT DATA

- **GENERAL**
- **DELIVERY SCHEDULE**
- **PAYMENT SCHEDULE**

The Contract Data is a part of General Conditions of Contract and should be read in conjunction with the General Conditions of Contract.

If there is a discrepancy found in the General Conditions of Contract and the Contract Data, the Content in the Contract Data shall supersede the Content in the General Conditions of Contract.

(Note: What is typed in italic letters are guide lines to prepare the Bidding Data and they shall be removed after preparation of the Bidding Data.)

Contract Data

Contract Data is a part of Condition of Contract and shall be read together. If any discrepancy is found content of the Contract Data shall supersede the Conditions of Contract

General Conditions of Contract Clause Reference Number

- 1.1 (d) Contract period from the date of acceptance of bid is days

- 3.2 The Engineer's Representative shall be the
of the National Water Supply and Drainage Board.

- 10.1 The Goods shall be delivered at such places, in such quantities and within such periods as prescribed in the attached Delivery Schedule.

- 15.2 The validity of warranty shall beYears from the date of final acceptance of the goods.

- 16.1 The maximum amount of Advance Payment shall be twenty percent (20%) of the Contract Price.

Advance payment Guarantee shall be obtained at the contractor's cost.

- 23.1 The amount of liquidated damages shall be Rs..... per day of delay.

- 31.1 Purchaser's address for notice purposes shall be as follows:

General Manager/ Project Director/ Deputy General Manager
National Water Supply and Drainage Board,
.....
.....,*(Insert Relevant Address)*

Facsimile Number : Colombo,
E Mail :

Supplier's address for notice purposes shall be as follows:

.....
.....
.....

DELIVERY SCHEDULE

Item	Description of Goods	Quantity	Final Destination <i>[insert place of Delivery]</i>	Delivery Date
				Purchaser's delivery date as per the contract
01	Bill No.1			
02	Bill No. 2			

PAYMENT SCHEDULE

STAGE OF PAYMENT		STAGE OF CONTRACT	DOCUMENT TO BE SUBMITTED	AMOUNT OF PAYMENT	REMARKS
01	Advance Payment	After signing of Contract Agreement	<ul style="list-style-type: none"> ◆ A written request for payment in the form of an invoice ◆ A bank guarantee for the equivalent amount ◆ A performance Guarantee 	20% of the contract price	Advance payment shall be made within <u>30 days</u> of signing the Contract upon submission of required documents.
02	Final Payment	Final Acceptance by the Engineer for the delivery and other obligations	<p>a). A written request for final (balance) payment in the form of an invoice based on the BOQ.</p> <p>b). Engineer's approval for the payment</p>	Total Contract Sum less previous payments including any advance payment made	The total Contract Sum shall become payable within <u>28 days</u> from the date of the Engineers Final Acceptance Certificate.

6. SPECIFICATION

7. KEY FEATURES OF SPECIFICATIONS

Item No.	Description	Requested Specification	
1	Type of stop valve	According to BS 1010: part 2 & Supplied drawing No. xx	
2	Markings on the body	Trade name of the product	
		BS number	
		Nominal size	
		Flow direction	
3 i	Material Composition of Brass for excluding die castings for body & components	Metallic parts must be of Brass of BS 1400	SCB 1
			SCB 3
			DCB 1
			DCB 3
			PCB 1
3 ii	Material composition of Brass for gravity die casting for body & components	Confirm to BS 1400 DCB 3	
		Equivalent grade in BSEN 1982:1999	
3 iii	Material composition of Brass for pressure die casting for body & components	Confirm to BS 1400 PCB 1	
		Equivalent grade in BSEN 1982:1999	
3 iv	Material composition of Brass for hot pressing for body & components	Confirm to BS 2872 CZ 122	
		Equivalent grade in BSEN 12420:1999	
4	Material composition of Washers	Vulcanized synthetic Rubber complying with clause 06 of BS 3457	
5	Head Seals	Fiber joint washers to BS 1010	
6	O-rings	Comply with appendix A to E os BS 1010	
7	Jointing materials & components for portable water installations	Comply with BS 5292/ BS 6956	
Construction			
1	Seat	Seat shall be integrally cast in the body & machined	
2	Threads	Inlet & outlet threads should be female BS pipe parallel threads with nominal size as the valve	
3 i	Head seal (When O-rings use)	Dimensions as per BS 1806 or BS 4578	
		Rubber components confirm to Appendix A of BS 1010	

Item No.	Description	Requested Specification
3 ii	Head seal (for flat seats)	Shall made from specially selected fiber complying with BS 1737 or BS 3964
4	Washer Plate & Washer plate unit	Washer plate & stem as one piece
		Washer plate shall have a stud for the attachment of the washers or screwed
		Valve plate shall be free to rotate in the hole in the spindle
		Top of the washer plate shall be clear of the bottom of the head when fully open
5	Method of attaching the handle	Handle shall be fixed on a squared spindle or the handle with secured on a serrated spindle or similar positively engaging method
		Handle shall be a close sliding without shaking
		Fixed by on axial screw with the handle on a sliding fit on the spindle
6	Spindle	Rising type
7	Clearance between head & handle	According to table 5 and 6 of BS 1010
8	Seat Washer	Comply with Clause 6 of BS 3457
9	Gland packing	It should be suitable for portable water
		Minimum with 2 O-rings with comply with Appendix A of BS 1010 and dimensions according to BS 1806 or BS 4518
		O – rings shall be not less than 1.6mm in sectional diameter

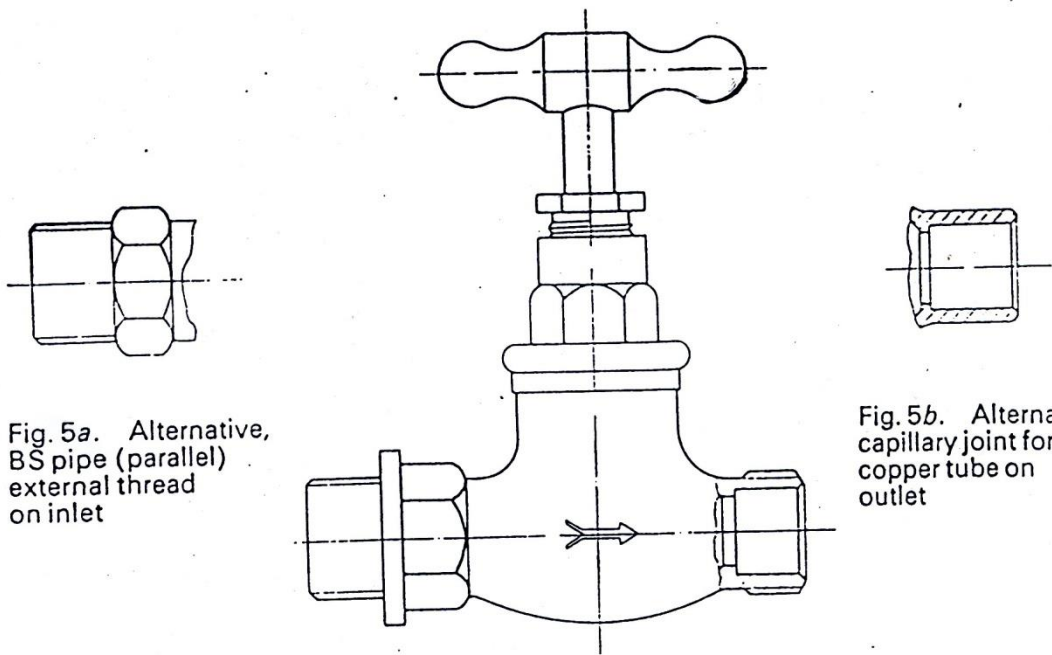

Fig. 5a. Alternative, BS pipe (parallel) external thread on inlet

Fig. 5b. Alternative, capillary joint for copper tube on outlet

Fig. 5. Stopvalve with BS pipe (parallel) external thread on inlet, compression joint for copper tube on outlet

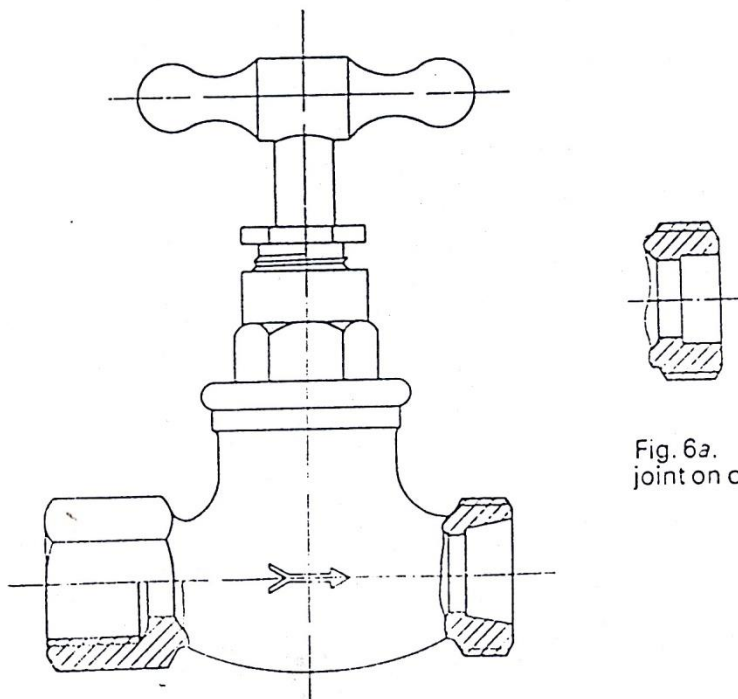

Fig. 6a. Alternative, washer union joint on outlet

Fig. 6. Stopvalve with BS pipe (parallel) internal thread on inlet, conical union joint on outlet

8. DEVIATIONS FROM SPECIFICATIONS

DEVIATIONS FROM SPECIFICATIONS

Preamble

The Bidder is required to list any deviations of Equipments, Accessories and workmanship etc. from the Specifications including such information as has already been given elsewhere in the Tender Documents. The information shall be in sufficient detail to enable the Engineer to make a realistic assessment of the effect of such deviations on the performance and also such deviation if any shall be subject to **Clause 24.2 (a)** of Instructions to Bidders.

Deviations

9. SCHEDULE OF PARTICULARS

1. Notes on Schedule of Particulars

- a) The bidder shall complete fully the schedule of particulars given in the bidding document for Brass Stop valves. The bid is liable to be rejected if the required details are not furnished.
- b) where catalogues, technical literature and drawings accompanying the bid, their references should be quoted in the Schedule of Particulars;
- c) Where the bidder's specification is not conforming to the minimum specification given in the bidding document, the offer will be rejected.
- d) All test reports specified by the Board shall be submitted at the time of delivery of materials at the stores and the supply of materials shall not be considered as complete for purpose of payment until the material is tested and accepted by the Engineer.

SCHEDULE OF PARTICULARS

- 1.1 Country of Manufacture:

- 1.2 Name and Address of the Manufacturer:

- 1.3 Factory Address:

- 1.4 Standards to which Brass stop valves conform:

- 1.5 Is Certificate for conformity to standards of relevant standards Institution provided:

- 1.6 Name & Address of the Inspection Agency selected for inspection and testing of Brass stop valves to be supplied under this contract:

- 1.7 Is ISO 9001: 2015 Quality Management System Certificate provided?

- 1.8 Date of Manufacture

- 1.9 Materials:
 - Body:
 - Spindle:
 - Washers:
 - Gland:
 - Others:

- 1.10 Body test pressure:

- 1.11 Seat test pressure

- 1.12 Names of water work facilities where these products had been used

- 1.13 Make:
- 1.14 Model Number:
- 1.15 Nominal Size:
- 1.16 Inlet/ Outlet thread type/specification:
- 1.17 Relevant BS Standard Number:
- 1.18 Type of valve(Rising spindle/Non rising spindle type)
- 1.19 No of samples submitted
- 1.20 Port of shipment :
- 1.21 Packing and protection in transit :
- 1.22 Time of delivery:
- 1.23 Reference of the catalogues, technical literature, drawing provided with the bid:
- 1.24 Name and address of the Supplier's agent in Sri Lanka:

10. BILLS OF QUANTITIES

- **PREAMBLE NOTES ON PRICING**
- **BILLS OF QUANTITIES**
- **SUMMARY OF BILLS**
- **GRAND SUMMARY**

PREAMBLE NOTES ON PRICING

1. General

- 1.1 The Bidder's attention is specifically directed to the Form of Bid, Instructions to Bidders, Conditions of Contract, Bidding Data, Contract Data, Delivery Schedule, Schedule of Particulars, Specifications and Key Features of Specifications which are to be read in conjunction with the Bills of Quantities. The following notes are given to assist in pricing the Bills of Quantities and enable the supplier to arrive at the total Bid Price. The Bidder shall insert rates and prices for the supply and delivery of **Brass Stop Valves** in strict accordance with the specifications.

2. Description of Items

- 2.1 Descriptions attached to the items in the Bills of Quantities are only in sufficient detail to ensure identification of the work described in the specifications.

3. Rates and prices

- 3.1 In pricing the items of the Bills of Quantities, the bidder shall cover himself and will be deemed to have covered himself for:
- a) All services and goods which according to the true intent and meaning of the contract may be reasonably inferred as necessary for completion of delivery of the materials in sound condition to the Stores which is specified in Contract data.
 - b) All the duties, obligations, liabilities and responsibilities which the Contract documents place upon the bidders in connection with or in relation to the Contract.
- 3.2 The bidder shall include in his bid price, for;
- a) Cost of goods, all costs arising out of inspection and testing, packing, insurance shipping line charge [Terminal Handling Charges (THC) and container deposit], cleaning, delivering, and stacking etc, warehouse rent and other charges custom duties, Port dues payable to the Department of Customs, and Sri Lanka Ports Authority, Any Port Rent and demurrage etc in connection with or in relation to the contract.
 - b) Cost of minor expenses items not specifically listed, but necessary for proper supply, delivery, unloading stacking, etc.

4. Unit rates accepted by the Employer shall be held good and effective until the supply is completed and accepted by the Employer.
5. A rate and/or amount is to be entered against each item in the Bill of Quantities whether quantities are stated or not. The cost of any item against which a rate has not been entered shall be deemed to be covered by other contract rates.
6. The materials covered by items in the Bills of Quantities are as detailed in the Specifications.
8. The rates and/or prices entered against items in the Bills of Quantities shall be excluding the VAT as the VAT is considered separately

NATIONAL WATER SUPPLY AND DRAINAGE BOARD
SUPPLY AND DELIVERY OFmmNOS
BRASS STOP VALVES

CONTRACT No.

BILL No. 01

Note: (1) Brass Stop Valves shall conform to the specification given in the Bidding document.

Item No.	Description	Qty	Unit	Rate LKR	Amount LKR
1.	Supply & Delivery of Brass Stop Valves				
1.1	½" (15 mm)		nr		
1.2		nr		
1.3		nr		
	Total of page Carried to Summary of Bills.				

**SUPPLY AND DELIVERY OFmm.....NOS
BRASS STOP VALVES**

CONTRACT NO.

SUMMARY OF BILLS

Bill No.	Description	Unit	Amount LKR
01	Supply & delivery of Brass Stop Valves	-	
02	Nominated Inspection and Testing by Independent Inspection Agency	Sum	
A	Sub Total 1 carried forward to Grand Summary		

**SUPPLY AND DELIVERY OFmm.....NOS
BRASS STOP VALVES**

CONTRACT NO.

GRAND SUMMARY

Bill No.	Description	Amount LKR
A	Sub Total 1	
B	Less Discount (if any)	
C	Sub Total 2 (A-B)	
D	Grand Total C carried to Form of Bid (Excluding VAT)	
E	VAT (.....%)	
F	Grand Total including VAT (D+E)	

VAT Registration Number:.....

(A copy of the VAT registration certificate shall be annexed.)

Note: - The NWSDB VAT Registration No: - 4090 31820 7000

11. SPECIMEN FORMS

- **BID SECURITY**
- **CONTRACT AGREEMENT**
- **PERFORMANCE SECURITY**
- **ADVANCE PAYMENT GUARANTEE**
- **LETTER OF ACCEPTANCE**

FORM OF BID SECURITY (Unconditional)

..... [issuing agency's name, and address of issuing branch or office]
.....
.....

Beneficiary : Chairman/Deputy General Manager/ Project Director
.....
.....
.....(Insert Relevant Address)

Date..... BID SECURITY No :

We have been informed that
[name of the Bidder ; if joint venture, list complete legal names of partners] (hereinafter called "the Bidder") has submitted to you its bid dated [insert date] (hereinafter called "the Bid") for the execution / supply of [name of contract] under Contract No.....

Furthermore, we understand that, according to your conditions, Bids must be supported by a Bid Security.

At the request of the Bidder, we
[name of issuing agency] hereby irrevocably under take to pay you any sum or sums not exceeding in total an amount of [amount in figures][amount in words] upon receipt by us of your first demand in writing accompanied by a written statement stating that the Bidder is in breach of its obligation (s) under the bid conditions, because of the Bidder:

- (a). has withdrawn its Bid during the period of bid validity specified ; or
- (b). does not accept the correction of errors in accordance with the Instructions to Bidders (hereinafter "the ITB") or
- (c). having been notified of the acceptance of its Bid by the Employer/ Purchaser during the period of Bid validity, (i) fails or refuses to execute the Contract Form, if required, or (ii) fails or refuses to furnish the Performance Security, in accordance with the ITB.

This Security shall expire: (a) if the Bidder is the successful bidder, upon our receipt of copies of the Contract signed by the Bidder and of the Performance Security issued to you by the Bidder, or (b) if the Bidder is not the successful bidder, upon the earlier of (i) our receipt of a copy of your notification to the Bidder that the Bidder was unsuccessful, otherwise it will remain in force up to [insert date].

Consequently, any demand of payment under this Security must be received by us the office on or before that date.....

.....
[Signature (s) of authorized representative (s)]

THE GOVERNMENT OF THE DEMOCRATIC SOCIALIST REPUBLIC OF SRI LANKA

MINISTRY OF

NATIONAL WATER SUPPLY AND DRAINAGE BOARD

TENDER FOR THE SUPPLY AND DELIVERY OF BRASS STOP VALVES

CONTRACT No.:

CONTRACT AGREEMENT

Contract Agreement made and entered into between the National Water Supply and Drainage Board, a corporate body duly established under the provisions of the National Water Supply and Drainage Board Law No. 2 of 1974 and having its Head Office at Ratmalana in Sri Lanka (hereinafter sometimes referred to as "the Board") of the one part and Messrs :

.....
.....which duly incorporated under the laws of Democratic Socialist Republic of Sri Lanka and having registered It's office at

.....
..... (hereinafter called "the Contractor" which term of expression shall where the context so requires or admits mean and include its successors and permitted assigns) of the other part.

WHEREAS the Board is desirous of entering into a contract with the Contractor for the supply and delivery of Brass Stop Valves to the Board at locations as specified in the Delivery Schedule and has accepted a Bid by the Contractor for the execution and completion of such works.

AND WHEREAS the Bills of Quantities or Schedule of Rates and Specifications and General Conditions of Contract describing the goods to be supplied have been prepared by the Board and the same have been signed by the parties hereto.

NOW it is hereby agreed as follows:

1. For the consideration hereinafter mentioned the Contractor shall, upon and subject to the conditions hereto annexed, complete the Works referred to in the said Bills of Quantities or Schedule of Rates and in the said Specifications and Conditions of Contract to the entire satisfaction of the

Board on or before the
.....
subject to extras, omissions and variations to be determined by the Engineer as hereinafter provided.

2. The said General Conditions of Contract, the said Specifications, the said Bills of Quantities or Schedule of Rates, (a detailed list whereof is annexed hereto,) Instructions to Bidders, Contract data, Bid Data and Schedule of Particulars and Form of Bid, all duly signed by the Board and the Contractor shall for all purposes whatsoever be read, regarded and construed as part and parcel of the Agreement.

3. The Contractor will be paid for the said execution of the Works the sum of
(Rs.) hereinafter sometimes referred to as the "Contract Price" or such as shall become payable hereunder according to the terms of the Contract.

4. As security for the due and proper performance and fulfillment of this contract and for the due payment of all claims to which the Board may be entitled hereunder, the Contractor hereby undertakes to maintain to the Board with a Guarantee in favor of the Board from a Bank approved by the Engineer, as surety in the sum of Sri Lanka Rupees
.....(in word)(in figures)
which said Performance Guarantee shall remain in force and shall not be discharged until the Engineer shall have granted a Final Certificate to the effect that the Contractor has duly discharged and completed all his obligations under this contract and that there is no sum whatever due to the Board at the date of such Final Acceptance Certificate under this Contract.

IN WITNESS WHEREOF the parties hereto have set their hands and seal to these presents at the places and dates hereinafter mentioned.

Signed by the said
Chairman, National Water Supply and Drainage Board/Project
Director..... WSP/Deputy General Manager-RSC.....
and..... Board Member of the
National Water Supply and Drainage Board/.....
(Name/Designation)of..... WSP/
(Name/Designation)of..... RSC.....at.....
.....on the.....
.....day.....of.....
.....Two Thousand and
.....in the presence of the following Witnesses.

.....
Chairman/Deputy General Manager/
Project Director

.....
Board Member/
of.....WSP/.....of
RSC.....

NATIONAL WATER SUPPLY AND DRAINAGE BOARD

WITNESSES

Signature 1:

Signature 2 :

Name :

Name :

Address
.....

Address :
.....

Capacity

Capacity

Signed by the said in the
capacity ofat.....on the
..... day of..... Two Thousand and
in the presence of the following Witnesses.

.....
Signature of Contractor

WITNESSES

.....
Seal

Signature 1:

Signature 2 :

Name :

Name :

Address
.....

Address
.....

Capacity

Capacity

FORM OF PERFORMANCE SECURITY (Unconditional)

.....[*Issuing Agency’s Name and Address of issuing Branch or Office*]
.....
.....

Beneficiary : Chairman/Deputy General Manager/ Project Director

.....
.....
.....(*Insert Relevant Address*)

Date

PERFORMANCE SECURITY No.:

We have been informed that
[*name of Contractor/Supplier*] (*hereinafter called “the Contractor”*) has entered into
Contract No. dated with you, for the
[*“Supply”*] of
[*name of contract and brief description of Works*] (*hereinafter called “the Contract”*).

Furthermore, we understand that according to the conditions of the Contract, a performance security is required.

At the request of the Contractor, we
[*name of Agency*] hereby irrevocably under take to pay you any sum or sums not exceeding
in total and amount of
.....[*in words*] And LKR..... (amount in
figures), such sum being payable in the types and proportions of currencies in which the
Contract Price is payable , upon receipt by us of your first demand in writing accompanied
by a written statement stating that the Contractor is in breach of its obligation (s) under the
Contract, without your needing to prove or to show grounds for your demand or the sums
specified therein.

This shall expire, no later than the day of , 20
[*28 Days beyond the scheduled contract completion date*] and any demand for payments
under it must be received by us at this office on or before that date.

.....
[*Signature (s)*]

Signature and seal of the guarantor

FORM OF ADVANCE PAYMENT SECURITY

.....[*Issuing Agency's Name and Address of issuing Branch or Office*]
.....
.....

Beneficiary : Chairman/Deputy General Manager/ Project Director
.....
.....
.....(*Insert Relevant Address*)

Date

ADVANCE PAYMENT SECURITY No.

We have been informed that
[*name of Contractor/Supplier*] (hereinafter called “the Contractor”) has entered in to
Contract No. dated with you, for the Supply of
.....[*name of Contract and brief
description*] (hereinafter called “the Contract”).

Furthermore, we understand that according to the conditions of Contract an advance payment
in the sum [*amount in figures*] (.....
.....) [*amount in words*] is to be made against an advance payment
security

At the request of the Contractor, we
[*issuing agency*] hereby irrevocably undertake to pay you any sum or sums not exceeding in
total and amount of [*amount in figures*] (.....
.....)[*amount in words*] upon receipt by us of your first
demand in writing accompanied by a written statement stating that the Contractor is in breach
of its obligation under the Contract.

The maximum amount of this security shall be progressively reduced by the amount of the
advance payment repaid by the Contractor.

This security shall expire on [28 Days beyond the Completion Date]

Consequently, any demand for payment under this security must be received by us at this
office on or before that date.

.....
[*Signature (s)*]

Signature and seal of the guarantor
Witness :

Name :

Address :

T&C/

.....
.....
.....

.....-20..

Regd. Post

Ms.
.....
.....

Dear Sirs,

**TENDER FOR SUPPLY & DELIVERY OFmmNO OF
BRASS STOP VALVES
CONTRACT NO:**

Letter of Acceptance

We are pleased to inform you that your offer submitted on(Date) on the above tender, amounting to Sri Lanka Rupees (LKR/=-) has been accepted.

- Applicable VAT will be payable on production of Tax Invoices. The Registered No. for NWSDB for VAT is 4090318207000.
- Brass Stop Valves should be from

Inspection and Testing of goods should be carried as per **Clause 8** of General Conditions of Contract with respect to quantity, quality and loading prior to shipment and certificates should be forwarded to Deputy General manager (.....)

All Brass Stop Valves under this contract shall be delivered at such places, in such quantities as specified in the Delivery Schedule and Contract Period is months from the date hereof.

The liquidated damages for any delay beyond the above period shall be LKR/=- per day not exceeding 10% of the total contract price.

An advance payment of 20% of the contract price could be obtained after signing the agreement on production of an advance payment guarantee in the prescribed format from a recognized bank operating in Sri Lanka approved by the Central Bank of Sri Lanka.

Performance Security in the form of guarantee in the prescribed format (a copy annexed) from a recognized bank operating in Sri Lanka approved by the Central Bank of Sri Lanka for an amount of 10% of the total Contract Price valid for a period of 28 Days beyond the contract period from the date hereof shall be submitted within 14 Days from the date hereof.

Performance security shall be denominated in the currency of contract and proportionate to the each currency.

Please acknowledge receipt of this letter by a return fax and make arrangements to sign the Agreement by prior appointment with the Asst. General Manager (Tenders & Contracts) within 28 Days.

Engineer's Representative of this contract is

Please contact Deputy General Manager (.....)/.....(Name/ Designation) on Tele No. for further action on this contract.

Yours faithfully,
National Water Supply & Drainage Board

General Manager

- Cc: 1. Secretary, Ministry of
2. Auditor General – Duplicate offer and a copy of the Tender Board decision attached.
 3. Addl. General Manager (.....)
 4. Deputy General Manager (.....)
 5. Deputy General Manager (Finance)
 6. Deputy General Manager (IA)
 7. Asst. General Manager (.....)
 8. Chief Engineer (.....)
- Stores Copy

12. APPENDICES

APPENDIX 1- DETAILS OF SIMILAR MANUFACTURES COMPLETED WITHIN THE LAST FIVE YEARS AND ONGOING

Name and Address of Employer	Name and details of Contract	Value of Contract	Period of Contract	Remarks (Completed/ ongoing etc)	Value of work remaining incomplete

APPENDIX 2 – FINANCIAL STATEMENT

Summary of assets and liabilities based on the audited financial statements for the last three financial years (Current statement may be unaudited) together with the Financial Performance as indicated in the following schedule shall be submitted.

If the business has not been in operation for three years following schedule shall be submitted for the period that the business has been in operation together with the aforesaid financial statements.

Bidders whose financial capability is marginally less to undertake this bid may show credit facilities available to them from a Banks. (see note below).

Financial performance for the last 3 years

Year	XXXX	XXXX	XXXX
Turnover from Contracting			
Fixed Assets (FA)			
Current Assets (CA)			
Current Liabilities (CL)			
Long Term Liabilities (LL)			
Net Worth = Total Assets – Total Liabilities			
Current Ratio = $\frac{\text{Current Assets}}{\text{Current Liability}}$			
Liquidity Ratio = $\frac{\text{Current Assets(except stock)}}{\text{Current Liability}}$			
Gearing Ratio = $\frac{\text{Debt Capital} \times 100}{\text{Total Capital Employed}}$			
$\frac{\text{Turnover}}{\text{Total Operating Assets}} \times 100$			
$\frac{\text{Net Profit}}{\text{Total Assets}} \times 100$			

APPENDIX 2A – AUTHORIZATION FOR BANK REFERENCES

BIDDER SHALL FILL THIS FORM AND PROVIDE WITH THE BID

..... *[Bidder's Name]*
.....*[Address]*
.....
.....

Manager *[Name of Bank]*
.....*[Address]*
.....
.....

We hereby Authorize the National Water Supply & Drainage Board, on behalf of the Procurement Committee, to seek references of Bank details in order to evaluate the financial statues of our company M/s.....
.....
[Bidder's Name & Address] in connections with the
.....
[Contract Name & Number] bid, submitted by us.

Yours faithfully,
.....
.....
Authorized officer of the Bidder.

Note : If there are more than one bank given, separate letters should be submitted for each Bank.

**APPENDIX 3 - MANUFACTURER'S AUTHORIZATION TO SIGN THE
BID/CONTRACT**

[The Bidder shall require the Manufacturer to fill in this Form in accordance with the instructions indicated. This letter of authorization should be on the letter head of the Manufacturer and should be signed by a person with the proper authority to sign documents that are binding on the Manufacturer. The bidder shall include it in its bid].

Date : [insert date (as day, month and year) of Bid Submission]
No. : [insert contract number]

To :
Chairman,
..... Procurement Committee,
.....,
.....,

Bid for Supply & Delivery of..... mm.....Nos Brass Stop Valves
Contract No.

We[insert complete name of Manufacturer], who are official manufacturers of Brass Stop Valves, having factories at[insert full address of Manufacturer's factories], do hereby authorize [insert complete name of Bidder] to submit a bid the purpose of which is to provide Brass Stop Valves manufactured by us and to subsequently negotiate and sign the Contract.

We hereby extend our full guarantee and warranty in accordance with **Clause 15** of the General Conditions of Contract, with respect to the Goods offered by the above firm.

Signed :[insert signature(s) of authorized representative(s) of the Manufacturer]

Name :[insert complete name(s) of authorized representative(s) of the Manufacturer]

Title : [insert title]

Duly authorized to sign this Contract on behalf of :[insert complete name of Manufacturer]

Dated on day of[insert date of signing].

APPENDIX 4 - CONFIRMATION OF CAPABILITY OF PRODUCTION AND SUPPLY ACCORDING TO DELIVERY SCHEDULE.

[Address of the Manufacturer]

.....
.....
.....

Chairman,
..... Procurement Committee,
.....,
.....,

Bid for Supply & Delivery of..... mm.....Nos Brass Stop Valves

Contract No.

We,[*name of manufacturer*]
of.....
.....

[*address of manufacturer*]confirm that we have sufficient production capacity to produce the quantity of Brass stop Valves submitted in our bid and shall deliver them according to the delivery schedule indicated in the bid.

.....
Authorised Officer of the Manufacturer.

.....
Seal of the Company.

Name :

Certified by

.....
Authorised Officer of the Bidder.

.....
Seal of the Company.

Name :

APPENDIX 5 - BIDDER'S AUTHORIZATION TO SIGN THE CONTRACT

[The Bidder shall require to fill in this Form in accordance with the instructions indicated. This letter of authorization should be on the letter head of the Bidder and should be signed by a person with the proper authority to sign documents that are binding on the Bidder. The bidder shall include it in its bid].

Date : [insert date (as day, month and year) of Bid Submission]
No. : [insert contract number]

Chairman,
..... Procurement Committee,
.....,
.....,

Bid for Supply & Delivery of..... mm.....Nos Brass Stop Valves
Contract No.

We[insert complete name of the Bidder], who
.....[insert full address of Bidder], do hereby
authorize [insert complete name of the Bidder's
authorized officer who signs the contract] to submit a bid on behalf of our company and to
subsequently negotiate and sign the Contract.

Specimen Signature

Signed :[insert signature(s) of authorized representative(s) of
the Bidder]

Name :[insert complete name(s) of
authorized representative(s) of the Bidder]

Title : [insert title]

Duly authorized to sign this Authorization on behalf of :
..... [insert complete name of Bidder]

This is to certify that the seal and signatures of legal representative and authorized person
affixed to power of attorney attached hereto are found to be authentic.

.....
Signature of Attorney at Law

.....
Seal of Attorney at Law

APPENDIX 6 - TOR FOR INDEPENDENT INSPECTION AGENCY

Item No.	Activity	Test Performed	Results	Acceptability as per Specification
1	Type of stop valve			
2	Markings on the body			
Material Composition				
3 i	Material Composition of Brass for excluding die castings for body & components			
3 ii	Material composition of Brass for gravity die casting for body & components			
3 iii	Material composition of Brass for pressure die casting for body & components			
3 iv	Material composition of Brass for hot pressing for body & components			
4	Material composition of Washers			
5	Head Seals			
6	O-rings			
7	Jointing materials & components for portable water installations			
Construction				
1	Seat			
2	Threads			
3 i	Head seal (When O-rings use)			
3 ii	Head seal (for flat seats)			
4	Washer Plate & Washer plate unit			
5	Method of attaching the handle			
6	Spindle			
7	Clearance between head & handle			
8	Seat Washer			
9	Gland packing			

APPENDIX 7 - MANUFACTURER'S AWARENESS OF THE TOR FOR INDEPENDENT INSPECTION AGENCY

[Address of the Manufacturer]

.....
.....
.....

Chairman,
..... Procurement Committee,
.....,
.....,

Bid for Supply & Delivery ofmm.....Nos Brass Stop Valves
Contract No.

We,[*name of manufacturer*] of
.....
.....[*address of manufacturer*]
confirm that we have noticed that

- a) Appendix 6 – TOR for Independent Inspection Agency.
- b) **Clause 8** of General Condition of Contract.

.....
Authorised Officer of the Manufacturer.
Name :

.....
Seal of the Company.

Certified by

.....
Authorised Officer of the Bidder.
Name :

.....
Seal of the Company.

**APPENDIX 8 - MANUFACTURER'S WARRANTY FOR THE GOODS
SUPPLIED UNDER THE CONTRACT**

[Address of the Manufacturer]

.....
.....

Chairman,
National Water Supply and Drainage Board,
Galle Road, Ratmalana, Sri Lanka.

Bid for Supply & Delivery ofmm.....Nos Brass Stop Valves

Contract No.

We,[*name of manufacturer*] of

.....
.....[*address of manufacturer*] warrant

that the goods supplied under this contract are new, unused, of the most recent or current models and have incorporated all recent improvements, and no defects arising out of the design, material or workmanship from any act that may be develop under normal use of the supplied goods.

If there is any defects during the warranty period specified in the **Clause 15** of the General Conditions of Contract, we shall attend to repair or replace the defective goods with all reasonable speed without any cost to the Purchaser.

.....

Authorised Officer of the Manufacturer.

.....

Seal of the Company.

Name :

Certified by

.....

Authorised Officer of the Bidder

.....

Seal of the Company.

Name :

APPENDIX 9 - SPECIMEN FORM OF TEST CERTIFICATE FOR PIPES AND FITTINGS

Customer:

Date:

Manufacturer:

Cert. No. :

Material to be tested : Pipes and fittings

Customer Order No. :

Identification of the Sample tested:

This is to certify that the inspection and testing of the above mentioned materials were duly made by us and in accordance with the specifications and the result was found satisfactory.
[The followings, which shall be the test results/compliance, shall be included in the test certificate]

1. Specification/Standard of conformity:
2. Appearance and shape :
 - i. Surface finish
 - ii. Check out roundness (ovality)
3. Physical properties
 - i. Tensile strength :
 - ii. Elongation :
 - iii. Hardness :
 - iv. Microstructure :
4. Metallurgical Analysis:
5. Dimensions :
 - i. Wall thickness
 - ii. Socket dimensions (drawing / sketch)
 - iii. Plain end chamfer details
6. Coating and Lining
Details of standards, composition and thickness of
 - i. External zinc coating :
 - ii. External bitumen coating :
 - iii. Cement mortar lining :
7. Pressure (Hydrostatic) tests:

APPENDIX 10 - MANUFACTURER'S GUARANTEE FOR THE REPLACEMENT OF UNACCEPTABLE GOODS SUPPLIED UNDER THE CONTRACT

[Address of the Manufacturer]

.....
.....

Chairman,
National Water Supply and Drainage Board,
Galle Road, Ratmalana, Sri Lanka.

Supply & Delivery of No. of Brass stop Valve

Contract No.....

We,[*name of manufacturer*] of
.....
.....[*address of manufacturer*] guarantee that we shall unconditionally undertake to replace any unacceptable goods supplied under this contract with no additional cost to the employer ensuring timely completion of the supplier.

If any case we fail to replace the unacceptable goods, we agree that the NWSDB shall not make balance 25% payment of foreign component and balance local component shall not be paid and encash the Performance Guarantee. We further aware that NWSDB will immediately suspend issuing bidding documents to us and thereafter action shall be taken to blacklist us.

.....
Authorised Officer of the Manufacturer

.....
Seal of the Company

Name :
Certified by

.....
Authorised Officer of the Bidder
Name :

.....
Seal of the Company

APPENDIX 11 - AFFIDAVIT BY THE BIDDER

I of being a (Buddhist or any other religionist), do hereby solemnly sincerely and truly declare and affirm as follows.

- 01. I am the Affirmant above named.

- 02. I hereby declare that I have applied for the contract of National Water Supply and Drainage Board bearing No: and my spouse or dependent does not work in National Water Supply and Drainage Board on permanent, casual or contract basis.

The foregoing affidavit having been read over and explained to the affirmant above named who having understood its nature content and context affirmed hereto and set his usual signature hereto in on this day of20.....

Before me

.....

Declarant

.....
Justice of the peace /
Commissioner for Oaths