

SPECIFICATION FOR BALL VALVES

Revised on 02-09-2017

TABLE OF CONTENTS

1	General	6p – 2 6p-3
2	Specification	6p – 3 6p-7

SPECIFICATION FOR uPVC BALL VALVES

1.0 General

A **ball valve** is a valve that opens by turning a handle attached to a ball inside the valve. The ball has a hole, or port, through the middle so that when the port is in line with both ends of the valve, flow will occur (valve is in open position). When the valve is closed, the hole is perpendicular to the ends of the valve, and flow is blocked. The handle or lever will be inline with the port position letting you "see" the open position of the valve.

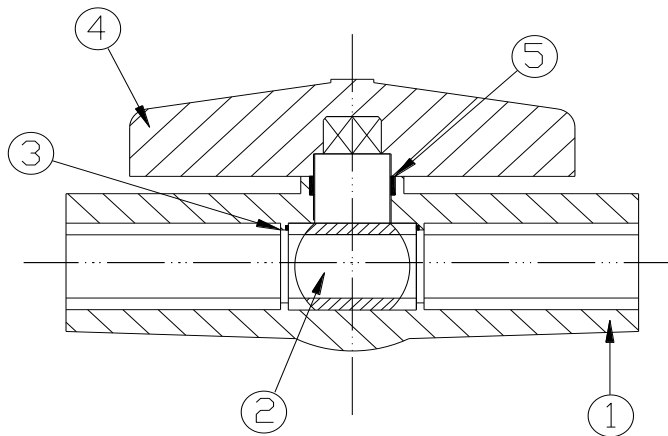

No	1	2	3	4	5
Part Name	Valve Body	Ball	Sealing Seat	Handle	O Ring
Qty	1	1	2	1	1

- 1.1 Ball valves shall comprise of a body on which head cap, handle, stem & ball assembly etc. with seat & stem O-ring mounted.
- 1.2 Ball valves shall provide leak free tight closure (complete– stop) of water flow through the valve in the closed position.
- 1.3 During operation seat & stem & ball assembly is moved causing the water to flowing through the valve.

- 1.4 All components shall be of “water works” standard and shall be of a well proven robust design and manufacture and shall be suitable for drinking water.
- 1.5 All non-metallic materials shall be listed in current “water fittings and materials directory” and shall be suitable for drinking water.

2.0 **Specification**

2.1 **General**

1. Body parts shall be uPVC & shall conform to EN 1452-1

2. **Appearance**

When viewed without magnification, the internal and external surfaces of valves and ancillaries shall be smooth, clean and free from scoring, cavities and other surface defects to an extent that would prevent conformity to this standard. Each end shall be square to its axis.

3. **Colour**

The colour of injection- moulded valve bodies and ancillaries in PVC-U shall be grey throughout the wall. The colour of ancillaries made from pipe shall be grey, blue or cream throughout the wall. For above-ground application, cream ancillaries shall not be used.

4. **Opacity**

The wall of the valve shall be opaque and shall not transmit more than 0.2% of visible light when measured in accordance with EN 578. This requirement does not apply to cream ancillaries

5. **Nominal dimensions**

The nominal diameter(s), of a valve and ancillaries shall correspond to, and be designated by, the nominal outside diameter(s) of the pipe(s) for which they are designed.

6. **Chemical Characteristics**

The chemical characteristics shall conform to those required for pipes by EN 1452- 2:1999

2.2 **Applicable Standards**

The Ball valves shall comply with BS EN 1452-4:2000 in every respect unless otherwise stated in the specifications.

2.3 Markings on the body

Ball valves shall be legibly and indelibly marked with the following, by embossing or engraving integrally during the process of manufacturing and shall comply with ASTM F 1970

1. Trade name of the product / Identification mark
2. BS or other equivalent standards
3. The nominal size and direction of flow
4. Nominal pressure and the temperature for which the pressure is applicable
5. Material designation

2.3.1 Additional Marking

Valves conforming to this standard, which conform also to other standard(s) may be additionally marked with minimum required marking in accordance with relevant standards. Documentary proof shall be provided for third party certificates.

2.4 Size

Sizes of the valves shall be as stated in the Bill of Quantities

2.5 Valve Components

	Item	Material Type	Description
01	Body	uPVC	Unplasticized Polyvinyl Chloride
02	Ball & stem	uPVC	Unplasticized Polyvinyl Chloride
03	Sealing Seat	PTEE	Poly Tetra Fluoro Ethylene (Teflon)
04	Handle	ABS	Acrylonitrile-Butadiene-Styrene Copolymer
05	Handle cap	ABS	Acrylonitrile-Butadiene-Styrene Copolymer
06	O ring	EPDM	EPT Rubber - Elastomeric product Ethylene Propylene Dyene Monomer

Composition of materials will be tested to verify the requirements in standards.

2.6 Construction of valve

1. Body, head and ball and stem
Injection molded and other methods of manufacture mentioned in the relevant standards of this specification are acceptable, if they satisfy other conditions included in the specifications.
2. Geometrical Characteristics
Dimension shall be accordance with Pr EN 496 as specified in BS EN 1452-4-2000.
3. Threads
Inlet & outlet threads shall be female BS pipe parallel threads of the nominal size as the valve and in compliance with BS 21.
4. Seat
Seat shall be of PTEE and shall conform to relevant BS or equivalent water work standards.
5. O- rings
Shall be of EPDM and shall conform to BS EN 681-1; 1996 or ISO 4633; 2002.

2.7 Testing

List of Tests

The list of tests carried out on the samples submitted with the offer and samples drawn from the delivered lots shall be in accordance with relevant BS or other standards.

2.7.1 Seat Test

Every Ball Valve in the closed position shall show no leakage when subjected to an internal hydrostatic pressure of 15 bar.

2.7.2 Body Test

In the open position and with the outlet sealed, shall be capable of withstanding without leakage an internally applied hydrostatic pressure of 15 bar.

Extracts from EN 1452-4: 1999, Table 10-Endurance properties and Table 12-Conditions for seat and packing test is shown elsewhere in this specification.

2.8 List of tests and standards requirements are as follows.

No	Test	Requirement in Standards
1	Appearance	The valve shall be homogeneous throughout and free of visible crack, holes, foreign inclusions or other defects as specified in ASTM D 2466-06
2	Dimension	Sealing Threads gauge correctly to BS ISO 7.1, Thread length and other dimensions & tolerance is compliant to ASTM D 2466 - 06
3	1000 Hrs Sustained Pressure Test	The test temperature between 15°C and 25°C with tolerance of $\pm 2C^\circ$, 1000 Hrs, No Leaking or crack in compliance with ASTM F 1970
4	Sealing Test	1.5 x PN, temperature between 15°C and 25°C with tolerance of $\pm 2C^\circ$, Sustained for 15 Seconds, No leaking.

2.9 Full details of the vales should be given in schedule of particulars.

2.10 Some of the salient features of the specifications are summarized above to furnish a quick reference. The tenderers are under obligations to refer the whole or relevant parts of the standards specified in their entirety prior to perfecting their tender documents, and will be deemed to have done so during the tendering stage.

Extracts from EN 1452-4 : 1999

Table 10-Endurance properties

Characteristic	Requirement ¹⁾	Test parameters		Test method
		parameter	value	
Endurance	No leakage or fracture during test period	Fluid inside internal pressure flow velocity Tightening of gland package Ambient temperature Number of test pieces Duration	Water Equal to PN 1 m/s Allowed (15 \pm 5) °C to (25 \pm 5) °C Shall conform to ENV 1452-7 1000 cycles	EN 28659
1) Directly after this endurance test the test pieces shall be tested in accordance with seat and packing test				

Table 12- Conditions for seat and packing test

Characteristic	Requirement	Test parameters		Test method
		Parameter	Value	
Seat Leak tightness: valve closed	No leakage during the test period	Fluid inside	Water	Method B of EN917: 1997
		Fluid out side	Air	
		Internal pressure	1.5 x [PN] ¹⁾	
Packing Leak tightness: valve open		Conditioning period	1h	
		Ambient temperature	(15 ± 5)° C to (25 ± 5) ° C	
		Test period	1 min	
1) Maximum test pressure ([PN] +5) bar.				